



## KV Small-type Distribution Boards up to 63 A

- 3 to 54 modules
- degree of protection IP 54 - 65
- made from thermoplastic material
- protection class II,
- in accordance with IEC 60 439-3

Assembling videos



### Assignment of box walls:

The assignment of box walls is effected via wall symbols that are assigned to each product. The individual figures **2** give an indication, which wall is concerned.



All box walls are listed in the fold-out of the coverpages.

### Box walls with membranes

#### Wall 1

3 x  $\varnothing$  7-16 mm



#### Wall 2

4 x  $\varnothing$  7-16 mm  
1 x  $\varnothing$  10-20 mm



#### Wall 3

4 x  $\varnothing$  7-16 mm  
2 x  $\varnothing$  10-20 mm  
1 x  $\varnothing$  10-24 mm



#### Wall 4

8 x  $\varnothing$  7-16 mm  
2 x  $\varnothing$  10-20 mm  
1 x  $\varnothing$  10-24 mm



#### Wall 5

8 x  $\varnothing$  7-12 mm  
8 x  $\varnothing$  7-14 mm  
4 x  $\varnothing$  12-20 mm  
1 x  $\varnothing$  16,5-29 mm

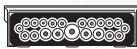

#### Wall 6

8 x  $\varnothing$  7-12 mm  
8 x  $\varnothing$  7-14 mm  
4 x  $\varnothing$  12-20 mm  
1 x  $\varnothing$  16,5-29 mm  
8 x M 20

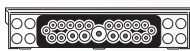

### Box walls with metric membranes

#### Wall 7

1 x M 20



#### Wall 8

3 x M 16



#### Wall 9

2 x M 20



#### Wall 10

2 x M 20  
1 x M 20/32



#### Wall 11

2 x M 20  
1 x M 20/32



#### Wall 12

4 x M 20  
1 x M 20/32



#### Wall 13

2 x M 20  
1 x M 25/32



#### Wall 14

2 x M 20/25  
1 x M 25/32



#### Wall 15

4 x M 20/25  
1 x M 25/32



#### Wall 16

2 x M 20  
2 x M 25  
1 x M 32/40



#### Wall 17

4 x M 20  
2 x M 20/25  
1 x M 32



#### Wall 18

12 x M 20  
2 x M 20/25  
1 x M 32



#### Wall 19

4 x M 20  
2 x M 25/32  
1 x M 32/40



#### Wall 20

6 x M 20  
2 x M 25/32  
1 x M 32/40



#### Wall 21

2 x AVS 16/  
EVS 16



### Box walls with cable glands for conduits and elastic membranes

#### Wall 22

8 x  $\varnothing$  M 16/20  
for conduit or cable  $\varnothing$  9-14 mm  
1 x M 25/32 for conduit or cable  
 $\varnothing$  18-24 mm, 6 x  $\varnothing$  9-18 mm



#### Wall 23

8 x  $\varnothing$  M 16/20  
for conduit or cable  $\varnothing$  9-14 mm,  
1 x M 25/32 for conduit or  
cable  $\varnothing$  18-24 mm, 6 x  $\varnothing$  9-18 mm,  
8 x M 20





**KV Small-type Distribution Boards 12-54 Modules**  
Cable entry via metric knockouts

139 - 147



**KV Small-type Distribution Boards 3-48 Modules**  
**"weatherproof"**,  
for outdoor installation  
(harsh environment and/or protected outdoor)

150 - 154



**KV Small-type Distribution Boards 12-48 Modules**  
Conduit entry via integrated membranes

156 - 158



**KV Extra Circuit-Breaker Boxes**  
with additional space for electrical devices not to be manually actuated  
  
Cable entry via metric knockouts

160 - 161



**Empty Boxes**  
  
with transparent lid  
with opaque hinged lid

163

164



**KWH Meter Boxes**

166



**Accessories**

168 - 173



**Technical Details**

175 - 181

with transparent lid 163  
with opaque hinged lid 164

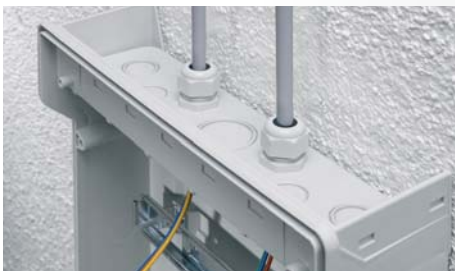

- Cable / Conduit entry via metric knock-outs



- KV Small-type distribution boards with earthed armored cables according to British Standard.



- Burning behaviour: Glow wire test according to IEC 60 695-2-11: 750 °C, flame-retardant, self-extinguishing



- FIXCONNECT® terminal technology for PE and N
- Connection for copper conductors



- 12 to 54 modules: attached blanking strips for DIN rail equipment openings.



- Integrated compartment for accessories - everything has its proper place.
- Screws made of stainless steel V2A.



**KV 7103**

**3 modules: 1 x 3 x 18 mm**

- 1-row
- knockouts: top and bottom walls 2x M20 each
- per PE/N number x cross section 1 x 25 mm<sup>2</sup>, 4 x 4 mm<sup>2</sup> Cu, FIXCONNECT® terminal technology, for terminal technology refer to technical data
- for the installation of DIN rail equipment, top hat profile 35 mm
- with transparent lid, sealable
- locking device for hinged lid and sealing facility see accessories
- with cable entry cover
- protective cover can be cut out

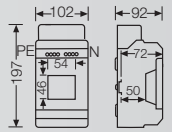

rated insulation voltage	AC 400 V
--------------------------	----------



**KV 6103**

**3 modules: 1 x 3 x 18 mm  
without PE and N terminal**

- 1-row
- knockouts: top and bottom walls 2x M20 each
- order PE/N terminals separately
- for the installation of DIN rail equipment, top hat profile 35 mm
- with transparent lid, sealable
- locking device for hinged lid and sealing facility see accessories
- with cable entry cover
- protective cover can be cut out

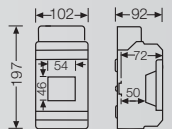

rated insulation voltage	AC 400 V
--------------------------	----------



**KV 7104**

**4.5 modules: 1 x 4.5 x 18 mm**

- 1-row
- knockouts: top and bottom walls 2x M20 and 1x M25/32 each
- per PE/N number x cross section 2 x 25 mm<sup>2</sup>, 4 x 4 mm<sup>2</sup> Cu, FIXCONNECT® terminal technology, for terminal technology refer to technical data
- for the installation of DIN rail equipment, top hat profile 35 mm
- with transparent lid, sealable
- locking device for hinged lid and sealing facility see accessories
- with cable entry cover
- protective cover can be cut out

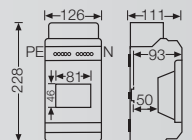

rated insulation voltage	AC 400 V
--------------------------	----------



**KV 6104**

**4.5 modules: 1 x 4.5 x 18 mm  
without PE and N terminal**

- 1-row
- knockouts: top and bottom walls 2x M20 and 1x M25/32 each
- order PE/N terminals separately
- for the installation of DIN rail equipment, top hat profile 35 mm
- with transparent lid, sealable
- locking device for hinged lid and sealing facility see accessories
- with cable entry cover
- protective cover can be cut out

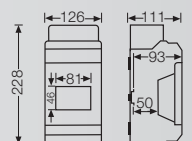

rated insulation voltage	AC 400 V
--------------------------	----------



**KV 7106**

**6 modules: 1 x 6 x 18 mm**

- 1-row
- knockouts: top and bottom walls 2x M20/25 and 1x M25/32 each
- per PE/N number x cross section 2 x 25 mm<sup>2</sup>, 4 x 4 mm<sup>2</sup> Cu, FIXCONNECT® terminal technology, for terminal technology refer to technical data
- for the installation of DIN rail equipment, top hat profile 35 mm
- with transparent lid, sealable
- locking device for hinged lid and sealing facility see accessories
- with cable entry cover
- protective cover can be cut out

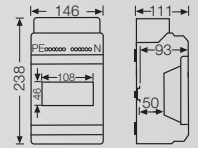

rated insulation voltage	AC 400 V
--------------------------	----------



**KV 6106**

**6 modules: 1 x 6 x 18 mm without PE and N terminal**

- 1-row
- knockouts: top and bottom walls 2x M20/25 and 1x M25/32 each
- order PE/N terminals separately
- for the installation of DIN rail equipment, top hat profile 35 mm
- with transparent lid, sealable
- locking device for hinged lid and sealing facility see accessories
- with cable entry cover
- protective cover can be cut out

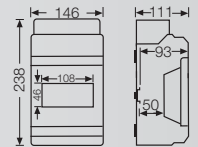

rated insulation voltage	AC 400 V
--------------------------	----------



**KV 7109**

**9 modules: 1 x 9 x 18 mm**

- 1-row
- knockouts: top and bottom walls 4x M20/25 and 1x M25/32 each
- per PE/N number x cross section 2 x 25 mm<sup>2</sup>, 8 x 4 mm<sup>2</sup> Cu, FIXCONNECT® terminal technology, for terminal technology refer to technical data
- for the installation of DIN rail equipment, top hat profile 35 mm
- with transparent lid, sealable
- locking device for hinged lid and sealing facility see accessories
- with cable entry cover
- protective cover can be cut out

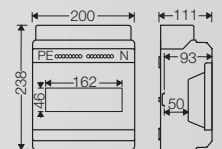

rated insulation voltage	AC 400 V
--------------------------	----------



**KV 6109**

**9 modules: 1 x 9 x 18 mm without PE and N terminal**

- 1-row
- knockouts: top and bottom walls 4x M20/25 and 1x M25/32 each
- order PE/N terminals separately
- for the installation of DIN rail equipment, top hat profile 35 mm
- with transparent lid, sealable
- locking device for hinged lid and sealing facility see accessories
- with cable entry cover
- protective cover can be cut out

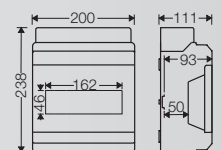

rated insulation voltage	AC 400 V
--------------------------	----------



**KV 9112 M**

**12 modules: 1 x 12 x 18 mm**

- 1-row
- per PE/N number x cross section 3 x 25 mm<sup>2</sup>, 12 x 4 mm<sup>2</sup> Cu, FIXCONNECT® terminal technology, for terminal technology refer to technical data
- N separable for various potentials
- for the installation of DIN rail equipment, top hat profile 35 mm
- with transparent door
- For locking device for door and facility for sealing refer to accessories.
- with cable entry cover
- with blanking strips for unused DIN rail openings
- knockouts: top and bottom walls 4x M20, 2x M20/25 and 1x M32 each

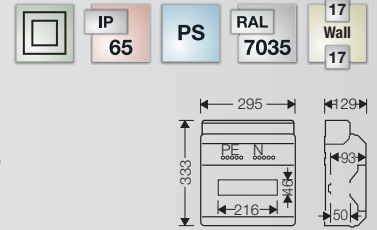

rated insulation voltage	AC 400 V
--------------------------	----------



**KV 8112 M**

**12 modules: 1 x 12 x 18 mm**  
**without PE and N terminal**

- 1-row
- order PE/N terminals separately
- for the installation of DIN rail equipment, top hat profile 35 mm
- with transparent door
- For locking device for door and facility for sealing refer to accessories.
- with cable entry cover
- with blanking strips for unused DIN rail openings
- knockouts: top and bottom walls 4x M20, 2x M20/25 and 1x M32 each

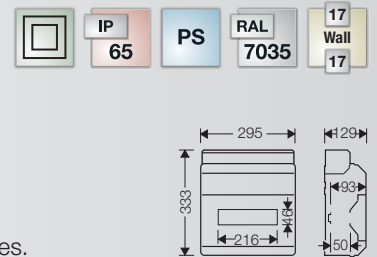

rated insulation voltage	AC 400 V
--------------------------	----------



**KV 1512 M**

**12 modules: 1 x 12 x 18 mm**

- 1-row
- per PE/N number x cross section 3 x 25 mm<sup>2</sup>, 12 x 4 mm<sup>2</sup> Cu, FIXCONNECT® terminal technology, for terminal technology refer to technical data
- N separable for various potentials
- for the installation of DIN rail equipment, top hat profile 35 mm
- with transparent door
- For locking device for door and facility for sealing refer to accessories.
- with cable entry cover
- with blanking strips for unused DIN rail openings
- knockouts: top and bottom walls 4x M20, 2x M20/25 and 1x M32 each

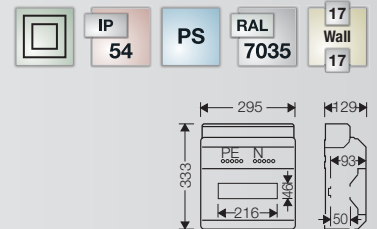

rated insulation voltage	AC 400 V
--------------------------	----------



**KV 1612 M**

**12 modules: 1 x 12 x 18 mm**  
**without PE and N terminal**

- 1-row
- order PE/N terminals separately
- for the installation of DIN rail equipment, top hat profile 35 mm
- with transparent door
- For locking device for door and facility for sealing refer to accessories.
- with cable entry cover
- with blanking strips for unused DIN rail openings
- knockouts: top and bottom walls 4x M20, 2x M20/25 and 1x M32 each

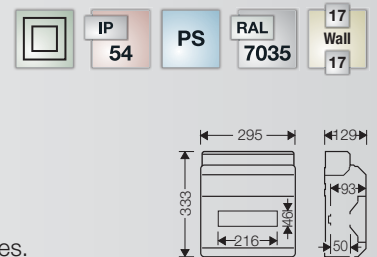

rated insulation voltage	AC 400 V
--------------------------	----------



**KV 9118 M**

**18 modules: 1 x 18 x 18 mm**

- 1-row
- per PE/N number x cross section 4 x 25 mm<sup>2</sup>, 16 x 4 mm<sup>2</sup> Cu, FIXCONNECT® terminal technology, for terminal technology refer to technical data
- N separable for various potentials
- for the installation of DIN rail equipment, top hat profile 35 mm
- with transparent door
- For locking device for door and facility for sealing refer to accessories.
- with cable entry cover
- with blanking strips for unused DIN rail openings
- knockouts: top and bottom walls 12x M20, 2x M20/25 and 1x M32 each

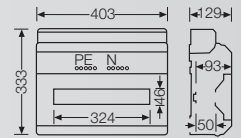

rated insulation voltage

AC 400 V



**KV 8118 M**

**18 modules: 1 x 18 x 18 mm  
without PE and N terminal**

- 1-row
- order PE/N terminals separately
- for the installation of DIN rail equipment, top hat profile 35 mm
- with transparent door
- For locking device for door and facility for sealing refer to accessories.
- with cable entry cover
- with blanking strips for unused DIN rail openings
- knockouts: top and bottom walls 12x M20, 2x M20/25 and 1x M32 each

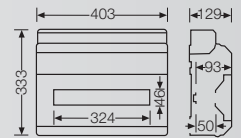

rated insulation voltage

AC 400 V



**KV 1518 M**

**18 modules: 1 x 18 x 18 mm**

- 1-row
- per PE/N number x cross section 4 x 25 mm<sup>2</sup>, 16 x 4 mm<sup>2</sup> Cu, FIXCONNECT® terminal technology, for terminal technology refer to technical data
- N separable for various potentials
- for the installation of DIN rail equipment, top hat profile 35 mm
- with transparent door
- For locking device for door and facility for sealing refer to accessories.
- with cable entry cover
- with blanking strips for unused DIN rail openings
- knockouts: top and bottom walls 12x M20, 2x M20/25 and 1x M32 each

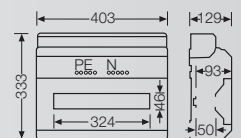

rated insulation voltage

AC 400 V



**KV 1618 M**

**18 modules: 1 x 18 x 18 mm  
without PE and N terminal**

- 1-row
- order PE/N terminals separately
- for the installation of DIN rail equipment, top hat profile 35 mm
- with transparent door
- For locking device for door and facility for sealing refer to accessories.
- with cable entry cover
- with blanking strips for unused DIN rail openings
- knockouts: top and bottom walls 12x M20, 2x M20/25 and 1x M32 each

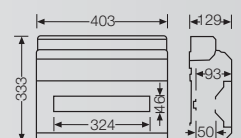

rated insulation voltage

AC 400 V



**KV 9224 M**

**24 modules: 2 x 12 x 18 mm**

- 2-row
- per PE/N number x cross section 6 x 25 mm<sup>2</sup>, 24 x 4 mm<sup>2</sup> Cu, FIXCONNECT® terminal technology, for terminal technology refer to technical data
- N separable for various potentials
- for the installation of DIN rail equipment, top hat profile 35 mm
- with transparent door
- For locking device for door and facility for sealing refer to accessories.
- with cable entry cover
- with blanking strips for unused DIN rail openings
- knockouts: top and bottom walls 4x M20, 2x M20/25 and 1x M32 each

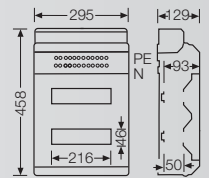

rated insulation voltage	AC 400 V
--------------------------	----------



**KV 8224 M**

**24 modules: 2 x 12 x 18 mm  
without PE and N terminal**

- 2-row
- order PE/N terminals separately
- for the installation of DIN rail equipment, top hat profile 35 mm
- with transparent door
- For locking device for door and facility for sealing refer to accessories.
- with cable entry cover
- with blanking strips for unused DIN rail openings
- knockouts: top and bottom walls 4x M20, 2x M20/25 and 1x M32 each

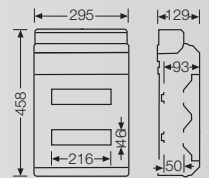

rated insulation voltage	AC 400 V
--------------------------	----------



**KV 2524 M**

**24 modules: 2 x 12 x 18 mm**

- 2-row
- per PE/N number x cross section 6 x 25 mm<sup>2</sup>, 24 x 4 mm<sup>2</sup> Cu, FIXCONNECT® terminal technology, for terminal technology refer to technical data
- N separable for various potentials
- for the installation of DIN rail equipment, top hat profile 35 mm
- with transparent door
- For locking device for door and facility for sealing refer to accessories.
- with cable entry cover
- with blanking strips for unused DIN rail openings
- knockouts: top and bottom walls 4x M20, 2x M20/25 and 1x M32 each

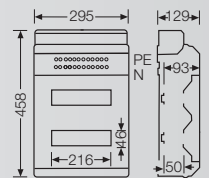

rated insulation voltage	AC 400 V
--------------------------	----------



**KV 2624 M**

**24 modules: 2 x 12 x 18 mm  
without PE and N terminal**

- 2-row
- order PE/N terminals separately
- for the installation of DIN rail equipment, top hat profile 35 mm
- with transparent door
- For locking device for door and facility for sealing refer to accessories.
- with cable entry cover
- with blanking strips for unused DIN rail openings
- knockouts: top and bottom walls 4x M20, 2x M20/25 and 1x M32 each

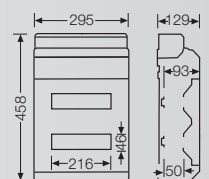

rated insulation voltage	AC 400 V
--------------------------	----------



**KV 9236 M**

**36 modules: 2 x 18 x 18 mm**

- 2-row
- per PE/N number x cross section 8 x 25 mm<sup>2</sup>, 32 x 4 mm<sup>2</sup> Cu, FIXCONNECT® terminal technology, for terminal technology refer to technical data
- N separable for various potentials
- for the installation of DIN rail equipment, top hat profile 35 mm
- with transparent door
- For locking device for door and facility for sealing refer to accessories.
- with cable entry cover
- with blanking strips for unused DIN rail openings
- knockouts: top and bottom walls 12x M20, 2x M20/25 and 1x M32 each

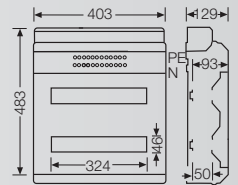

rated insulation voltage

AC 400 V



**KV 8236 M**

**36 modules: 2 x 18 x 18 mm**  
**without PE and N terminal**

- 2-row
- order PE/N terminals separately
- for the installation of DIN rail equipment, top hat profile 35 mm
- with transparent door
- For locking device for door and facility for sealing refer to accessories.
- with cable entry cover
- with blanking strips for unused DIN rail openings
- knockouts: top and bottom walls 12x M20, 2x M20/25 and 1x M32 each

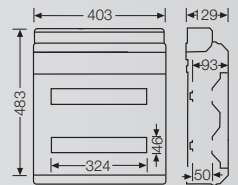

rated insulation voltage

AC 400 V



**KV 2536 M**

**36 modules: 2 x 18 x 18 mm**

- 2-row
- per PE/N number x cross section 8 x 25 mm<sup>2</sup>, 32 x 4 mm<sup>2</sup> Cu, FIXCONNECT® terminal technology, for terminal technology refer to technical data
- N separable for various potentials
- for the installation of DIN rail equipment, top hat profile 35 mm
- with transparent door
- For locking device for door and facility for sealing refer to accessories.
- with cable entry cover
- with blanking strips for unused DIN rail openings
- knockouts: top and bottom walls 12x M20, 2x M20/25 and 1x M32 each

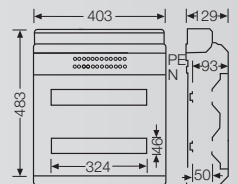

rated insulation voltage

AC 400 V



**KV 2636 M**

**36 modules: 2 x 18 x 18 mm**  
**without PE and N terminal**

- 2-row
- order PE/N terminals separately
- for the installation of DIN rail equipment, top hat profile 35 mm
- with transparent door
- For locking device for door and facility for sealing refer to accessories.
- with cable entry cover
- with blanking strips for unused DIN rail openings
- knockouts: top and bottom walls 12x M20, 2x M20/25 and 1x M32 each

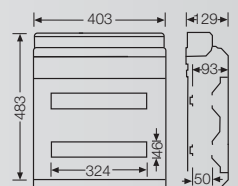

rated insulation voltage

AC 400 V



**KV 9336 M**

**36 modules: 3 x 12 x 18 mm**

- 3-row
- per PE/N number x cross section 6 x 25 mm<sup>2</sup>, 24 x 4 mm<sup>2</sup> Cu, FIXCONNECT® terminal technology, for terminal technology refer to technical data
- N separable for various potentials
- for the installation of DIN rail equipment, top hat profile 35 mm
- with transparent door
- For locking device for door and facility for sealing refer to accessories.
- with cable entry cover
- with blanking strips for unused DIN rail openings
- knockouts: top and bottom walls 4x M20, 2x M20/25 and 1x M32 each

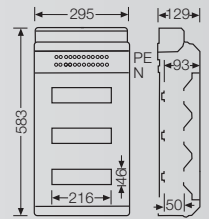

rated insulation voltage	AC 400 V
--------------------------	----------



**KV 8336 M**

**36 modules: 3 x 12 x 18 mm  
without PE and N terminal**

- 3-row
- order PE/N terminals separately
- for the installation of DIN rail equipment, top hat profile 35 mm
- with transparent door
- For locking device for door and facility for sealing refer to accessories.
- with cable entry cover
- with blanking strips for unused DIN rail openings
- knockouts: top and bottom walls 4x M20, 2x M20/25 and 1x M32 each

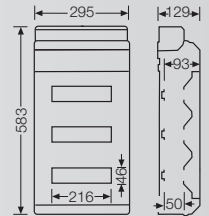

rated insulation voltage	AC 400 V
--------------------------	----------



**KV 3536 M**

**36 modules: 3 x 12 x 18 mm**

- 3-row
- per PE/N number x cross section 6 x 25 mm<sup>2</sup>, 24 x 4 mm<sup>2</sup> Cu, FIXCONNECT® terminal technology, for terminal technology refer to technical data
- N separable for various potentials
- for the installation of DIN rail equipment, top hat profile 35 mm
- with transparent door
- For locking device for door and facility for sealing refer to accessories.
- with cable entry cover
- with blanking strips for unused DIN rail openings
- knockouts: top and bottom walls 4x M20, 2x M20/25 and 1x M32 each

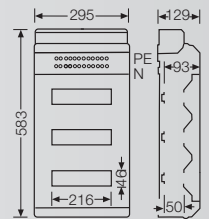

rated insulation voltage	AC 400 V
--------------------------	----------



**KV 3636 M**

**36 modules: 3 x 12 x 18 mm  
without PE and N terminal**

- 3-row
- order PE/N terminals separately
- for the installation of DIN rail equipment, top hat profile 35 mm
- with transparent door
- For locking device for door and facility for sealing refer to accessories.
- with cable entry cover
- with blanking strips for unused DIN rail openings
- knockouts: top and bottom walls 4x M20, 2x M20/25 and 1x M32 each

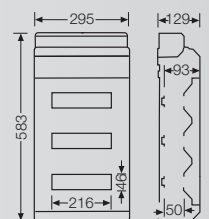

rated insulation voltage	AC 400 V
--------------------------	----------



**KV 9448 M**

**48 modules: 4 x 12 x 18 mm**

- 4-row
- per PE/N number x cross section 6 x 25 mm<sup>2</sup>, 24 x 4 mm<sup>2</sup> Cu, FIXCONNECT® terminal technology, for terminal technology refer to technical data
- N separable for various potentials
- for the installation of DIN rail equipment, top hat profile 35 mm
- with transparent door
- For locking device for door and facility for sealing refer to accessories.
- with cable entry cover
- with blanking strips for unused DIN rail openings
- knockouts: top and bottom walls 4x M20, 2x M20/25 and 1x M32 each

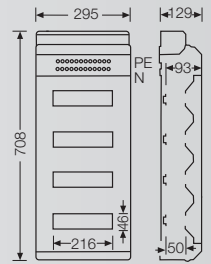

rated insulation voltage	AC 400 V
--------------------------	----------



**KV 8448 M**

**48 modules: 4 x 12 x 18 mm**  
**without PE and N terminal**

- 4-row
- order PE/N terminals separately
- for the installation of DIN rail equipment, top hat profile 35 mm
- with transparent door
- For locking device for door and facility for sealing refer to accessories.
- with cable entry cover
- with blanking strips for unused DIN rail openings
- knockouts: top and bottom walls 4x M20, 2x M20/25 and 1x M32 each

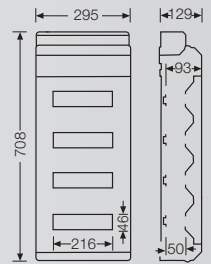

rated insulation voltage	AC 400 V
--------------------------	----------



**KV 4548 M**

**48 modules: 4 x 12 x 18 mm**

- 4-row
- per PE/N number x cross section 6 x 25 mm<sup>2</sup>, 24 x 4 mm<sup>2</sup> Cu, FIXCONNECT® terminal technology, for terminal technology refer to technical data
- N separable for various potentials
- for the installation of DIN rail equipment, top hat profile 35 mm
- with transparent door
- For locking device for door and facility for sealing refer to accessories.
- with cable entry cover
- with blanking strips for unused DIN rail openings
- knockouts: top and bottom walls 4x M20, 2x M20/25 and 1x M32 each

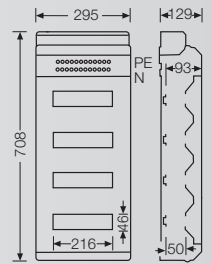

rated insulation voltage	AC 400 V
--------------------------	----------



**KV 4648 M**

**48 modules: 4 x 12 x 18 mm**  
**without PE and N terminal**

- 4-row
- order PE/N terminals separately
- for the installation of DIN rail equipment, top hat profile 35 mm
- with transparent door
- For locking device for door and facility for sealing refer to accessories.
- with cable entry cover
- with blanking strips for unused DIN rail openings
- knockouts: top and bottom walls 4x M20, 2x M20/25 and 1x M32 each

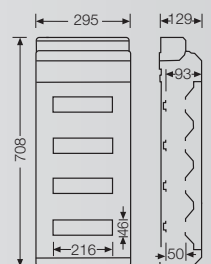

rated insulation voltage	AC 400 V
--------------------------	----------



**KV 9354 M**

**54 modules: 3 x 18 x 18 mm**

- 3-row
- per PE/N number x cross section 8 x 25 mm<sup>2</sup>, 32 x 4 mm<sup>2</sup> Cu, FIXCONNECT® terminal technology, for terminal technology refer to technical data
- N separable for various potentials
- for the installation of DIN rail equipment, top hat profile 35 mm
- with transparent door
- For locking device for door and facility for sealing refer to accessories.
- with cable entry cover
- with blanking strips for unused DIN rail openings
- knockouts: top and bottom walls 12x M20, 2x M20/25 and 1x M32 each

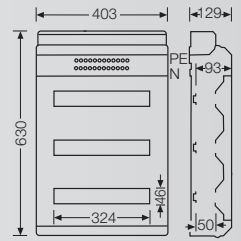

rated insulation voltage

AC 400 V



**KV 8354 M**

**54 modules: 3 x 18 x 18 mm  
without PE and N terminal**

- 3-row
- order PE/N terminals separately
- for the installation of DIN rail equipment, top hat profile 35 mm
- with transparent door
- For locking device for door and facility for sealing refer to accessories.
- with cable entry cover
- with blanking strips for unused DIN rail openings
- knockouts: top and bottom walls 12x M20, 2x M20/25 and 1x M32 each

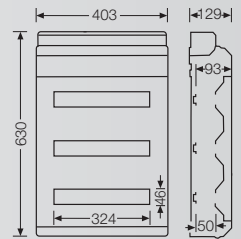

rated insulation voltage

AC 400 V



**KV 3554 M**

**54 modules: 3 x 18 x 18 mm**

- 3-row
- per PE/N number x cross section 8 x 25 mm<sup>2</sup>, 32 x 4 mm<sup>2</sup> Cu, FIXCONNECT® terminal technology, for terminal technology refer to technical data
- N separable for various potentials
- for the installation of DIN rail equipment, top hat profile 35 mm
- with transparent door
- For locking device for door and facility for sealing refer to accessories.
- with cable entry cover
- with blanking strips for unused DIN rail openings
- knockouts: top and bottom walls 12x M20, 2x M20/25 and 1x M32 each

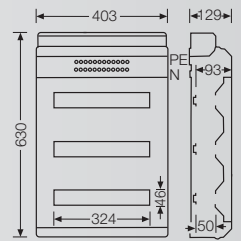

rated insulation voltage

AC 400 V



**KV 3654 M**

**54 modules: 3 x 18 x 18 mm  
without PE and N terminal**

- 3-row
- order PE/N terminals separately
- for the installation of DIN rail equipment, top hat profile 35 mm
- with transparent door
- For locking device for door and facility for sealing refer to accessories.
- with cable entry cover
- with blanking strips for unused DIN rail openings
- knockouts: top and bottom walls 12x M20, 2x M20/25 and 1x M32 each

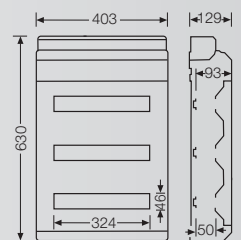

rated insulation voltage

AC 400 V

**„Weatherproof“,  
for Outdoor Installation (harsh Environment and/or Outdoor)**

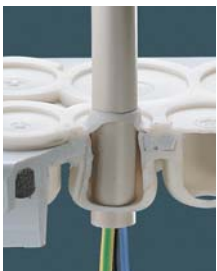
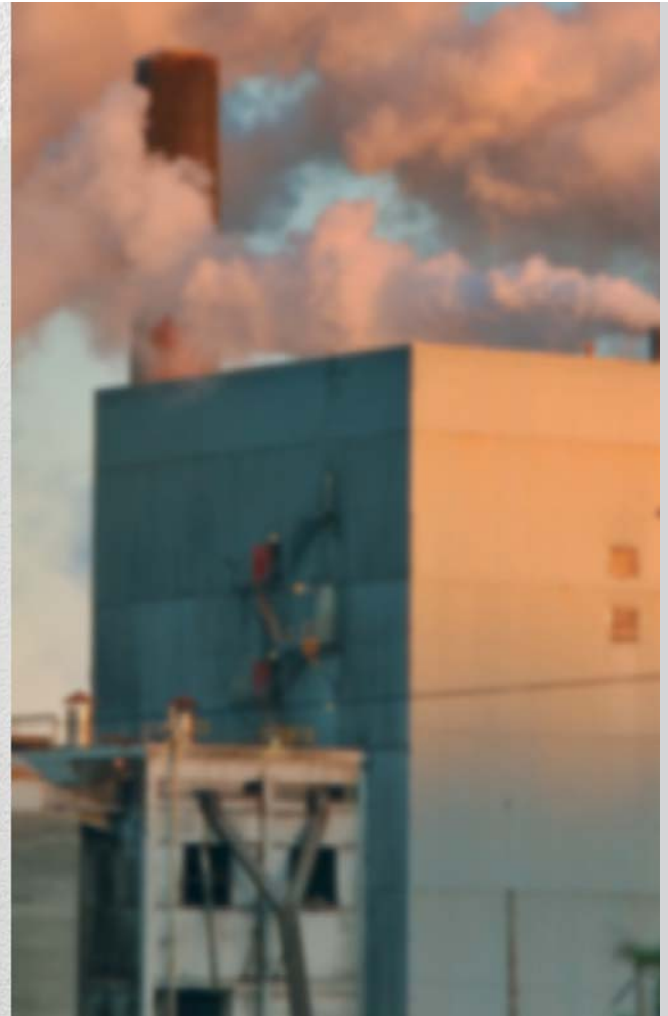

- Cable entry via integrated elastic membranes or
- via metric knockouts



- 12 to 54 modules: attached blanking strips for DIN rail equipment openings.
- 3 to 9 modules: protective cover can be cut out

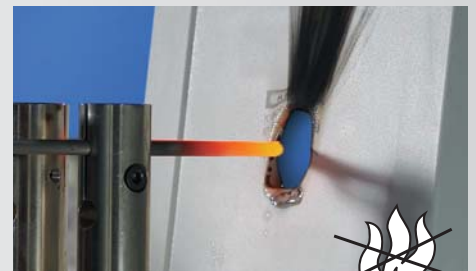

- Burning behaviour: Glow wire test according to IEC 60 695-2-11: 960 °C, flame-retardant, self-extinguishing



- FIXCONNECT® terminal technology for PE and N
- connection for copper conductors

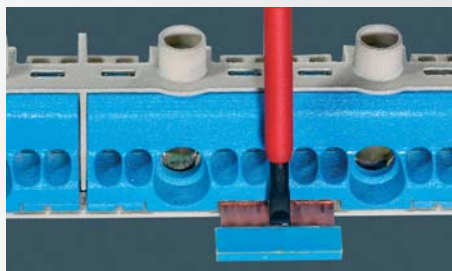

- KV Small-type distribution boards with up to four disconnectable N-potentials in one bar enable the installation of RCDs without additional efforts or accessories.



- Integrated compartment for accessories - everything has its proper place.
- Screws made of stainless steel V2A.

**„Weatherproof“,  
for Outdoor Installation (Harsh Environment and/or Outdoor)**

The enclosures are suitable for the outdoor installation - harsh environment and / or outdoor.

The materials used for the system are basically UV resistant, so that the mechanical resistance of the boxes is maintained during UV effect.

**Direct solar radiation and power dissipation can overheat the interior of the enclosure. Also affect lower outdoor temperatures, e.g. below -5 ° C, the device technology. Therefore, the climatic influences and effects on the device technology must be considered.**

The top side of the boxes should be protected by a cover against weather influences such as rain, ice and snow. Further on, also chemical influences have to be considered with the selection of the installation place - apart from the IP rating and climatic effects.

In order to keep the maximum permissible ambient temperature of the installed equipment as well as for the prevention from condensation additional measures, such as ventilation and/or heating may be necessary (observe degree of protection).

**How does condensed water occur in enclosures with a high degree of protection?**

The problem of condensed water forming in electrical installations only occurs in enclosures with a degree of protection  $\geq$  IP 54 since the temperature adjustment that is carried out from inside to outside is too low due to the high density of the enclosure and its material.

System switched on.

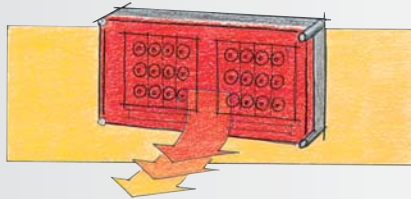

The internal temperature is higher than the external temperature due to the power dissipation of the built-in devices.

System switched on.

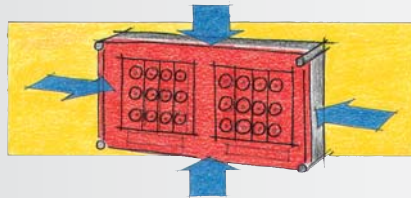

The warm air inside the enclosure attempts to accumulate moisture. This comes from outside through the seal as the enclosures are not gas-tight.

System switched off.

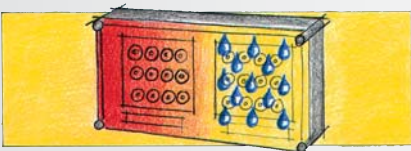

The internal temperature is reduced by cooling down the system e.g. by switching off the loads. The cooler air emits moisture which is collected as condensed water on the cooling inner surfaces.

**How does condensed water occur in enclosures with a high degree of protection?**

Formation of condensed water for **indoor installations:**

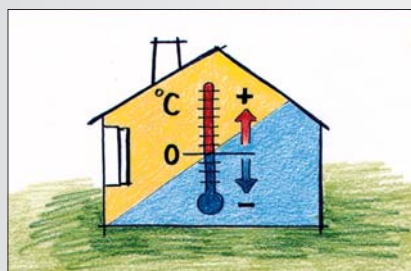

In areas where high levels of air humidity and large temperature fluctuations are expected e.g. in laundry rooms, kitchens, car washes etc.

Formation of condensed water in **protected outdoor installations** (protected against weather influences) **or unprotected outdoor installations:**

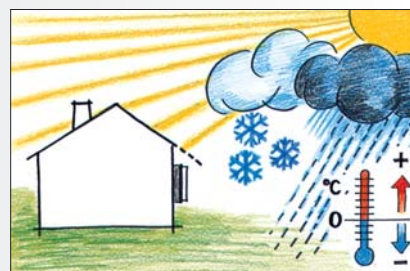

Here condensed water can be formed dependent on the weather, high air humidity, direct sunlight and temperature differences compared to the wall.

**„Weatherproof“,**

**for Outdoor Installation (harsh Environment and/or Outdoor)**



**KV PC 9103**

**3 modules: 1 x 3 x 18 mm**



- 1-row
- knockouts: top and bottom walls 2x M20 each
- per PE/N number x cross section 1 x 25 mm<sup>2</sup>, 4 x 4 mm<sup>2</sup> Cu, FIXCONNECT® terminal technology, for terminal technology refer to technical data
- for indoor (normal environment and/or protected outdoor) and outdoor installation (harsh environment and/or outdoor)
- for the installation of DIN rail equipment, top hat profile 35 mm
- with transparent lid, sealable
- locking device for hinged lid and sealing facility see accessories
- with cable entry cover
- protective cover can be cut out

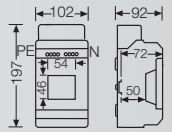

rated insulation voltage	AC 400 V
--------------------------	----------



**KV PC 6103**

**3 modules: 1 x 3 x 18 mm without PE and N terminal**



- 1-row
- knockouts: top and bottom walls 2x M20 each
- order PE/N terminals separately
- for indoor (normal environment and/or protected outdoor) and outdoor installation (harsh environment and/or outdoor)
- for the installation of DIN rail equipment, top hat profile 35 mm
- with transparent lid, sealable
- locking device for hinged lid and sealing facility see accessories
- with cable entry cover
- protective cover can be cut out

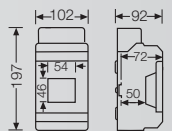

rated insulation voltage	AC 690 V DC 1000 V
--------------------------	-----------------------



**KV PC 9104**

**4.5 modules: 1 x 4.5 x 18 mm**



- 1-row
- knockouts: top and bottom walls 2x M20 and 1x M25/32 each
- per PE/N number x cross section 2 x 25 mm<sup>2</sup>, 4 x 4 mm<sup>2</sup> Cu, FIXCONNECT® terminal technology, for terminal technology refer to technical data
- for indoor (normal environment and/or protected outdoor) and outdoor installation (harsh environment and/or outdoor)
- for the installation of DIN rail equipment, top hat profile 35 mm
- with transparent lid, sealable
- locking device for hinged lid and sealing facility see accessories
- with cable entry cover
- protective cover can be cut out

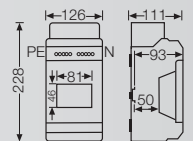

rated insulation voltage	AC 400 V
--------------------------	----------

**„Weatherproof“,  
for Outdoor Installation (harsh Environment and/or Outdoor)**



**KV PC 6104**

**4.5 modules: 1 x 4.5 x 18 mm  
without PE and N terminal**

- 1-row
- knockouts: top and bottom walls 2x M20 and 1x M25/32 each
- order PE/N terminals separately
- for indoor (normal environment and/or protected outdoor) and outdoor installation (harsh environment and/or outdoor)
- for the installation of DIN rail equipment, top hat profile 35 mm
- with transparent lid, sealable
- locking device for hinged lid and sealing facility see accessories
- with cable entry cover
- protective cover can be cut out

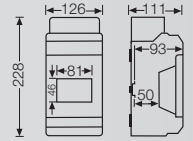

rated insulation voltage	AC 690 V DC 1000 V
--------------------------	-----------------------



**KV PC 8104**

**4.5 modules: 1 x 4.5 x 18 mm  
without PE and N terminal**

- 1-row
- order PE/N terminals separately
- for indoor (normal environment and/or protected outdoor) and outdoor installation (harsh environment and/or outdoor)
- for the installation of DIN rail equipment, top hat profile 35 mm
- with transparent lid, sealable
- locking device for hinged lid and sealing facility see accessories
- with cable entry cover
- protective cover can be cut out
- box walls without knockouts

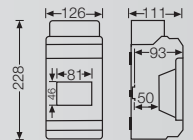

rated insulation voltage	AC 690 V DC 1000 V
--------------------------	-----------------------



**KV PC 9106**

**6 modules: 1 x 6 x 18 mm**

- 1-row
- knockouts: top and bottom walls 2x M20/25 and 1x M25/32 each
- per PE/N number x cross section 2 x 25 mm<sup>2</sup>, 4 x 4 mm<sup>2</sup> Cu, FIXCONNECT® terminal technology, for terminal technology refer to technical data
- for indoor (normal environment and/or protected outdoor) and outdoor installation (harsh environment and/or outdoor)
- for the installation of DIN rail equipment, top hat profile 35 mm
- with transparent lid, sealable
- locking device for hinged lid and sealing facility see accessories
- with cable entry cover
- protective cover can be cut out

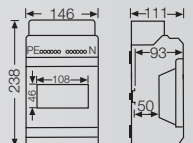

rated insulation voltage	AC 400 V
--------------------------	----------

„Weatherproof“,

for Outdoor Installation (harsh Environment and/or Outdoor)

ENVYCASE®

ENVYBOARD



**KV PC 6106**

**6 modules: 1 x 6 x 18 mm  
without PE and N terminal**



- 1-row
- knockouts: top and bottom walls 2x M20/25 and 1x M25/32 each
- order PE/N terminals separately
- for indoor (normal environment and/or protected outdoor) and outdoor installation (harsh environment and/or outdoor)
- for the installation of DIN rail equipment, top hat profile 35 mm
- with transparent lid, sealable
- locking device for hinged lid and sealing facility see accessories
- with cable entry cover
- protective cover can be cut out

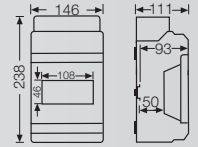

rated insulation voltage	AC 690 V DC 1000 V
--------------------------	-----------------------



**KV PC 9109**

**9 modules: 1 x 9 x 18 mm**



- 1-row
- knockouts: top and bottom walls 4x M20/25 and 1x M25/32 each
- per PE/N number x cross section 2 x 25 mm<sup>2</sup>, 8 x 4 mm<sup>2</sup> Cu, FIXCONNECT® terminal technology, for terminal technology refer to technical data
- for indoor (normal environment and/or protected outdoor) and outdoor installation (harsh environment and/or outdoor)
- for the installation of DIN rail equipment, top hat profile 35 mm
- with transparent lid, sealable
- locking device for hinged lid and sealing facility see accessories
- with cable entry cover
- protective cover can be cut out

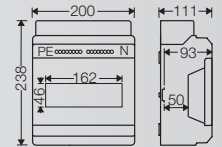

rated insulation voltage	AC 400 V
--------------------------	----------



**KV PC 6109**

**9 modules: 1 x 9 x 18 mm  
without PE and N terminal**



- 1-row
- knockouts: top and bottom walls 4x M20/25 and 1x M25/32 each
- order PE/N terminals separately
- for indoor (normal environment and/or protected outdoor) and outdoor installation (harsh environment and/or outdoor)
- for the installation of DIN rail equipment, top hat profile 35 mm
- with transparent lid, sealable
- locking device for hinged lid and sealing facility see accessories
- with cable entry cover
- protective cover can be cut out

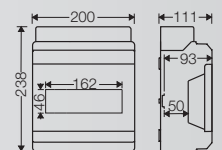

rated insulation voltage	AC 400 V DC 1000 V
--------------------------	-----------------------

**„Weatherproof“,  
for Outdoor Installation (harsh Environment and/or Outdoor)**



**KV PC 8109**

**9 modules: 1 x 9 x 18 mm  
without PE and N terminal**

- 1-row
- order PE/N terminals separately
- for indoor (normal environment and/or protected outdoor) and outdoor installation (harsh environment and/or outdoor)
- for the installation of DIN rail equipment, top hat profile 35 mm
- with transparent lid, sealable
- locking device for hinged lid and sealing facility see accessories
- with cable entry cover
- protective cover can be cut out
- box walls without knockouts

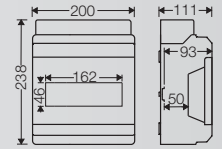

rated insulation voltage	AC 690 V DC 1000 V
--------------------------	-----------------------



**KV PC 9112**

**12 modules: 1 x 12 x 18 mm**

- 1-row
- cable entry via integrated elastic membranes
- per PE/N number x cross section 3 x 25 mm<sup>2</sup>, 12 x 4 mm<sup>2</sup> Cu, FIXCONNECT® terminal technology, for terminal technology refer to technical data
- N separable for various potentials
- for indoor (normal environment and/or protected outdoor) and outdoor installation (harsh environment and/or outdoor)
- for the installation of DIN rail equipment, top hat profile 35 mm
- with transparent door
- For locking device for door and facility for sealing refer to accessories.
- with cable entry cover
- with blanking strips for unused DIN rail openings
- lateral enclosure connections can be managed by drilling

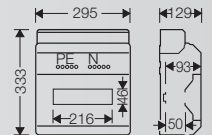

rated insulation voltage	AC 400 V
--------------------------	----------



**KV PC 9224**

**24 modules: 2 x 12 x 18 mm**

- 2-row
- cable entry via integrated elastic membranes
- per PE/N number x cross section 6 x 25 mm<sup>2</sup>, 24 x 4 mm<sup>2</sup> Cu, FIXCONNECT® terminal technology, for terminal technology refer to technical data
- N separable for various potentials
- for indoor (normal environment and/or protected outdoor) and outdoor installation (harsh environment and/or outdoor)
- for the installation of DIN rail equipment, top hat profile 35 mm
- with transparent door
- For locking device for door and facility for sealing refer to accessories.
- with cable entry cover
- with blanking strips for unused DIN rail openings
- lateral enclosure connections can be managed by drilling

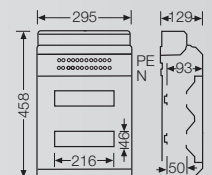

rated insulation voltage	AC 400 V
--------------------------	----------

**„Weatherproof“,**

**for Outdoor Installation (harsh Environment and/or Outdoor)**

ENVYCASE®



**KV PC 9336**

**36 modules: 3 x 12 x 18 mm**



- 3-row
- cable entry via integrated elastic membranes
- per PE/N number x cross section 6 x 25 mm<sup>2</sup>, 24 x 4 mm<sup>2</sup> Cu, FIXCONNECT® terminal technology, for terminal technology refer to technical data
- N separable for various potentials
- for indoor (normal environment and/or protected outdoor) and outdoor installation (harsh environment and/or outdoor)
- for the installation of DIN rail equipment, top hat profile 35 mm
- with transparent door
- For locking device for door and facility for sealing refer to accessories.
- with cable entry cover
- with blanking strips for unused DIN rail openings
- lateral enclosure connections can be managed by drilling

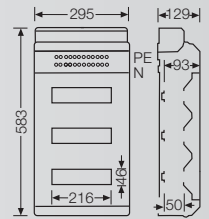

rated insulation voltage

AC 400 V

ENVYBOARD®



**KV PC 9448**

**48 modules: 4 x 12 x 18 mm**



- 4-row
- cable entry via integrated elastic membranes
- per PE/N number x cross section 6 x 25 mm<sup>2</sup>, 24 x 4 mm<sup>2</sup> Cu, FIXCONNECT® terminal technology, for terminal technology refer to technical data
- N separable for various potentials
- for indoor (normal environment and/or protected outdoor) and outdoor installation (harsh environment and/or outdoor)
- for the installation of DIN rail equipment, top hat profile 35 mm
- with transparent door
- For locking device for door and facility for sealing refer to accessories.
- with cable entry cover
- with blanking strips for unused DIN rail openings
- lateral enclosure connections can be managed by drilling

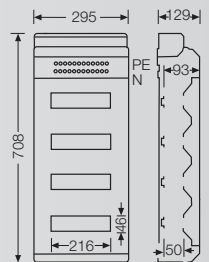

rated insulation voltage

AC 400 V



- Conduit entry via integrated elastic membranes



- Door hinging interchangeable fast and easy from left to right.

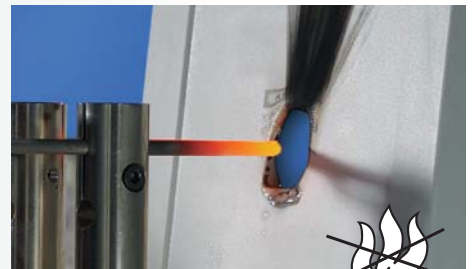

- Burning behaviour: Glow wire test according to IEC 60 695-2-11: 750 °C, flame-retardant, self-extinguishing



- 12 to 54 modules: attached blanking strips for DIN rail equipment openings



- Plenty of space for installation and wiring: Easy access to built-in equipment by lower side walls.



- Integrated compartment for accessories - everything has its proper place.
- Screws made of stainless steel V2A.



**KV 1712**

**12 modules: 1 x 12 x 18 mm**

- 1-row
- per PE/N number x cross section 3 x 25 mm<sup>2</sup>, 12 x 4 mm<sup>2</sup> Cu, FIXCONNECT® terminal technology, for terminal technology refer to technical data
- N separable for various potentials
- for the installation of DIN rail equipment, top hat profile 35 mm
- with transparent door
- For locking device for door and facility for sealing refer to accessories.
- with cable entry cover
- with blanking strips for unused DIN rail openings
- with cable glands for conduits and elastic membranes

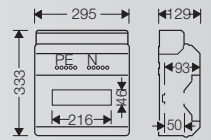

rated insulation voltage	AC 400 V
--------------------------	----------



**KV 1718**

**18 modules: 1 x 18 x 18 mm**

- 1-row
- per PE/N number x cross section 4 x 25 mm<sup>2</sup>, 16 x 4 mm<sup>2</sup> Cu, FIXCONNECT® terminal technology, for terminal technology refer to technical data
- N separable for various potentials
- for the installation of DIN rail equipment, top hat profile 35 mm
- with transparent door
- For locking device for door and facility for sealing refer to accessories.
- with cable entry cover
- with blanking strips for unused DIN rail openings
- with cable glands for conduits and elastic membranes

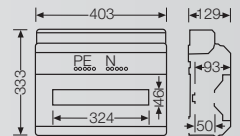

rated insulation voltage	AC 400 V
--------------------------	----------



**KV 2724**

**24 modules: 2 x 12 x 18 mm**

- 2-row
- per PE/N number x cross section 6 x 25 mm<sup>2</sup>, 24 x 4 mm<sup>2</sup> Cu, FIXCONNECT® terminal technology, for terminal technology refer to technical data
- N separable for various potentials
- for the installation of DIN rail equipment, top hat profile 35 mm
- with transparent door
- For locking device for door and facility for sealing refer to accessories.
- with cable entry cover
- with blanking strips for unused DIN rail openings
- with cable glands for conduits and elastic membranes

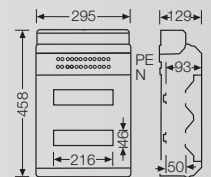

rated insulation voltage	AC 400 V
--------------------------	----------



**KV 2736**

**36 modules: 2 x 18 x 18 mm**

- 2-row
- per PE/N number x cross section 8 x 25 mm<sup>2</sup>, 32 x 4 mm<sup>2</sup> Cu, FIXCONNECT® terminal technology, for terminal technology refer to technical data
- N separable for various potentials
- for the installation of DIN rail equipment, top hat profile 35 mm
- with transparent door
- For locking device for door and facility for sealing refer to accessories.
- with cable entry cover
- with blanking strips for unused DIN rail openings
- with cable glands for conduits and elastic membranes

rated insulation voltage	AC 400 V
--------------------------	----------

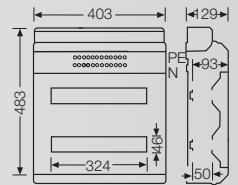

ENYCASE

ENYBOARD



**KV 3736**

**36 modules: 3 x 12 x 18 mm**

- 3-row
- per PE/N number x cross section 6 x 25 mm<sup>2</sup>, 24 x 4 mm<sup>2</sup> Cu, FIXCONNECT® terminal technology, for terminal technology refer to technical data
- N separable for various potentials
- for the installation of DIN rail equipment, top hat profile 35 mm
- with transparent door
- For locking device for door and facility for sealing refer to accessories.
- with cable entry cover
- with blanking strips for unused DIN rail openings
- with cable glands for conduits and elastic membranes

rated insulation voltage	AC 400 V
--------------------------	----------

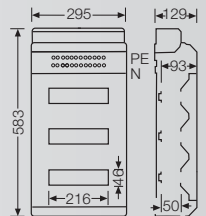

**KV 3754**

**54 modules: 3 x 18 x 18 mm**

- 3-row
- per PE/N number x cross section 8 x 25 mm<sup>2</sup>, 32 x 4 mm<sup>2</sup> Cu, FIXCONNECT® terminal technology, for terminal technology refer to technical data
- N separable for various potentials
- for the installation of DIN rail equipment, top hat profile 35 mm
- with transparent door
- For locking device for door and facility for sealing refer to accessories.
- with cable entry cover
- with blanking strips for unused DIN rail openings
- with cable glands for conduits and elastic membranes

rated insulation voltage	AC 400 V
--------------------------	----------

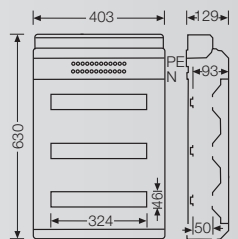



**KV 4748**

**48 modules: 4 x 12 x 18 mm**

- 4-row
- per PE/N number x cross section 6 x 25 mm<sup>2</sup>, 24 x 4 mm<sup>2</sup> Cu, FIXCONNECT® terminal technology, for terminal technology refer to technical data
- N separable for various potentials
- for the installation of DIN rail equipment, top hat profile 35 mm
- with transparent door
- For locking device for door and facility for sealing refer to accessories.
- with cable entry cover
- with blanking strips for unused DIN rail openings
- with cable glands for conduits and elastic membranes

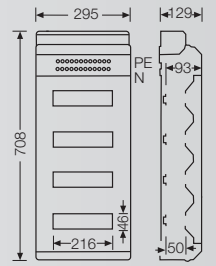

rated insulation voltage	AC 400 V
--------------------------	----------



- Compact user friendly solution, optically optimized.
- Pre-assembly and wiring are possible in the workshop when terminal blocks are provided for.



- Additional space with DIN rail over the total enclosure width for electrical devices not to be manually actuated. Installation depth 72 mm. Installation height max. 125 mm resp. 150 mm.



- DIN rail equipment (dimensions according to DIN 43 880) can be installed in the same enclosure.



- Cable / conduit entry via metric knockouts.



- Integrated compartment for accessories - everything has its proper place.
- Screws made of stainless steel V2A.

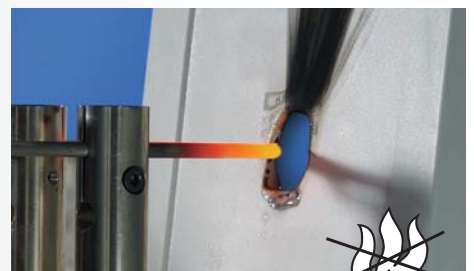

- Burning behaviour: Glow wire test according to IEC 60 695-2-11: 750 °C, flame-retardant, **self-extinguishing**



**KV 9220 M**

**12 modules: 1 x 12 x 18 mm**  
**without PE and N terminal**

- 1-row
- order PE/N terminals separately
- for the installation of DIN rail equipment, top hat profile 35 mm
- with additional space for electrical devices not to be manually actuated
- with 1 DIN rail, 273 mm wide, for DIN rail equipment and terminal blocks with max. mounting depth 72 mm
- with transparent door
- For locking device for door and facility for sealing refer to accessories.
- with cable entry cover
- with blanking strips for unused DIN rail openings
- knockouts: top and bottom walls 4x M20, 2x M20/25 and 1x M32 each

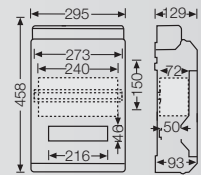

rated insulation voltage

AC 400 V



**KV 9230 M**

**18 modules: 1 x 18 x 18 mm**  
**without PE and N terminal**

- 1-row
- order PE/N terminals separately
- for the installation of DIN rail equipment, top hat profile 35 mm
- with additional space for electrical devices not to be manually actuated
- with 1 DIN rail, 381 mm wide, for DIN rail equipment and terminal blocks with max. mounting depth 72 mm
- with transparent door
- For locking device for door and facility for sealing refer to accessories.
- with cable entry cover
- with blanking strips for unused DIN rail openings
- knockouts: top and bottom walls 12x M20, 2x M20/25 and 1x M32 each

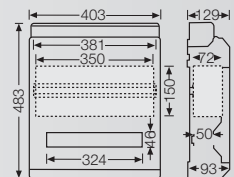

rated insulation voltage

AC 400 V



**KV 9330 M**

**24 modules: 2 x 12 x 18 mm**  
**without PE and N terminal**

- 2-row
- order PE/N terminals separately
- for the installation of DIN rail equipment, top hat profile 35 mm
- with additional space for electrical devices not to be manually actuated
- with 1 DIN rail, 273 mm wide, for DIN rail equipment and terminal blocks with max. mounting depth 72 mm
- with transparent door
- For locking device for door and facility for sealing refer to accessories.
- with cable entry cover
- with blanking strips for unused DIN rail openings
- knockouts: top and bottom walls 4x M20, 2x M20/25 and 1x M32 each

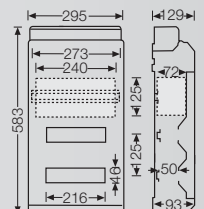

rated insulation voltage

AC 400 V



**KV 9440 M**

**36 modules: 3 x 12 x 18 mm**  
**without PE and N terminal**

- 3-row
- order PE/N terminals separately
- for the installation of DIN rail equipment, top hat profile 35 mm
- with additional space for electrical devices not to be manually actuated
- with 1 DIN rail, 273 mm wide, for DIN rail equipment and terminal blocks with max. mounting depth 72 mm
- with transparent door
- For locking device for door and facility for sealing refer to accessories.
- with cable entry cover
- with blanking strips for unused DIN rail openings
- knockouts: top and bottom walls 4x M20, 2x M20/25 and 1x M32 each

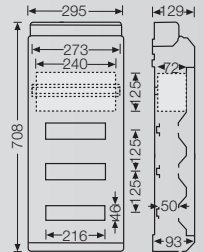

rated insulation voltage

AC 400 V



**KV 9350 M**

**36 modules: 2 x 18 x 18 mm**  
**without PE and N terminal**

- 2-row
- order PE/N terminals separately
- for the installation of DIN rail equipment, top hat profile 35 mm
- with additional space for electrical devices not to be manually actuated
- with 1 DIN rail, 381 mm wide, for DIN rail equipment and terminal blocks with max. mounting depth 72 mm
- with transparent door
- For locking device for door and facility for sealing refer to accessories.
- with cable entry cover
- with blanking strips for unused DIN rail openings
- knockouts: top and bottom walls 12x M20, 2x M20/25 and 1x M32 each

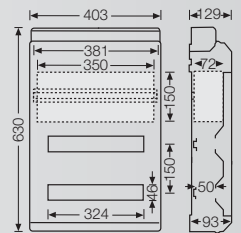

rated insulation voltage

AC 400 V



ENYBOARD  
ENYCASE



- KG empty boxes:  
Cable entry via metric knock outs.



- Cable entry via integrated elastic membranes.  
■ (except for KG Empty boxes)

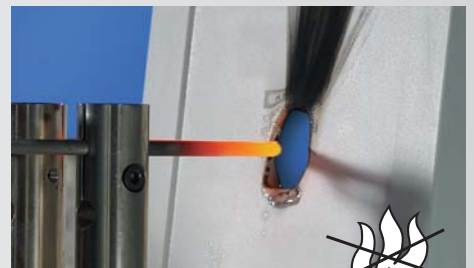

- Burning behaviour:  
Glow wire test according to IEC 60 695-2-11: 750 °C,  
flame-retardant, self-extinguishing



- Screws made of stainless steel V2A.

**KG 9001**

**Degree of protection: IP 55 (ESM),  
 IP 65 (refer to index cable entry systems)**

- for installation equipment on DIN rails or mounting plates
- max. installation depth with built-in mounting plate 95 mm, with built-in DIN rail 89 mm
- with transparent hinged lid
- fastener for tool operation
- sealable
- cable entry via metric knockouts
- included cable entry:  
 2 ESM 25, sealing range  $\varnothing$  9-17 mm and  
 1 ESM 32, sealing range  $\varnothing$  9-23 mm

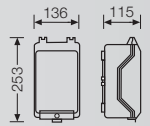

**KG 9002**

**Degree of protection: IP 55 (ESM),  
 IP 65 (refer to index cable entry systems)**

- for installation equipment on DIN rails or mounting plates
- max. installation depth with built-in mounting plate 95 mm, with built-in DIN rail 89 mm
- with transparent hinged lid
- fastener for tool operation
- sealable
- cable entry via metric knockouts
- included cable entry:  
 2 ESM 25, sealing range  $\varnothing$  9-17 mm and  
 1 ESM 32, sealing range  $\varnothing$  9-23 mm

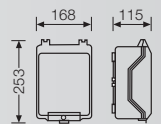

**KG 9003**

**Degree of protection: IP 55 (ESM),  
 IP 65 (refer to index cable entry systems)**

- for installation equipment on DIN rails or mounting plates
- max. installation depth with built-in mounting plate 95 mm, with built-in DIN rail 89 mm
- with transparent hinged lid
- fastener for tool operation
- sealable
- cable entry via metric knockouts
- included cable entry:  
 2 ESM 25, sealing range  $\varnothing$  9-17 mm and  
 1 ESM 32, sealing range  $\varnothing$  9-23 mm

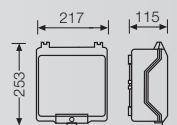

**KV 9331**

**Degree of protection: IP 65**

- for installation of devices via installed mounting plate
- max. installation depth: 160 mm
- with transparent lid
- fastener for tool operation
- sealable
- with cable entry cover
- cable entry via integrated elastic membranes

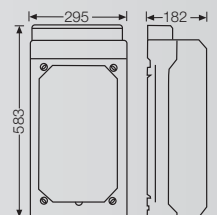



**KG 9001 IN**

**Degree of protection: IP 55 (ESM),  
 IP 65 (refer to index cable entry systems)**

- for installation equipment on DIN rails or mounting plates
- max. installation depth with built-in mounting plate 95 mm, with built-in DIN rail 89 mm
- with opaque hinged lid
- fastener for tool operation
- sealable
- cable entry via metric knockouts
- included cable entry:  
 2 ESM 25, sealing range Ø 9-17 mm and  
 1 ESM 32, sealing range Ø 9-23 mm

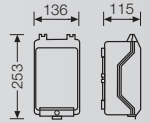

**KG 9002 IN**

**Degree of protection: IP 55 (ESM),  
 IP 65 (refer to index cable entry systems)**

- for installation equipment on DIN rails or mounting plates
- max. installation depth with built-in mounting plate 95 mm, with built-in DIN rail 89 mm
- with opaque hinged lid
- fastener for tool operation
- sealable
- cable entry via metric knockouts
- included cable entry:  
 2 ESM 25, sealing range Ø 9-17 mm and  
 1 ESM 32, sealing range Ø 9-23 mm

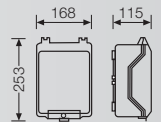

**KG 9003 IN**

**Degree of protection: IP 55 (ESM),  
 IP 65 (refer to index cable entry systems)**

- for installation equipment on DIN rails or mounting plates
- max. installation depth with built-in mounting plate 95 mm, with built-in DIN rail 89 mm
- with opaque hinged lid
- fastener for tool operation
- sealable
- cable entry via metric knockouts
- included cable entry:  
 2 ESM 25, sealing range Ø 9-17 mm and  
 1 ESM 32, sealing range Ø 9-23 mm

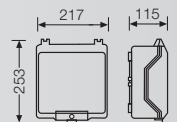
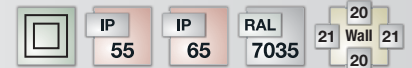



■ Cable entry with integrated elastic sealing membranes



■ Screws made of stainless steel V2A.

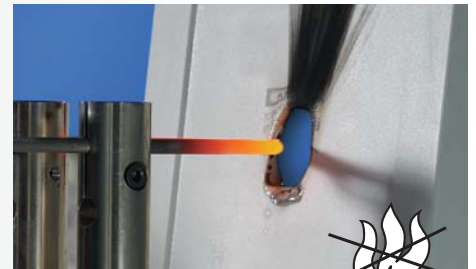

■ Burning behaviour:  
■ Glow wire test according to IEC 60 695-2-11: 750 °C, flame-retardant



■ Sealable



**KV 9337**

**Use in unmetered area after consultation with local power supply companies**  
**degree of protection: IP 65**

- with KWH meter support and meter fastening screws for meters with three-point mounting
- max. installation depth: 162 mm
- with hinged flap and protection cover for 12 modules (12 x 18 mm)
- with DIN-rail belonging to it
- with transparent lid
- fasteners for tool operation
- sealable
- with cable entry cover
- cable entry via integrated elastic membranes

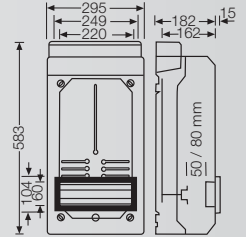

**KV 9338**

**Use in unmetered area after consultation with local power supply companies**  
**degree of protection: IP 54**

- with KWH meter support and meter fastening screws for meters with three-point mounting
- max. installation depth: 154 mm
- with KWH meter window flap, sealable
- for maximum KWH meters, time switches etc.
- standard opening dimensions 140 x 310 mm
- for tool or manual operation
- for padlock (clip Ø max. 6 mm)
- with additional DIN rail
- length of DIN rail 172 mm
- with transparent lid
- fasteners for tool operation
- sealable
- with cable entry cover
- cable entry via integrated elastic membranes

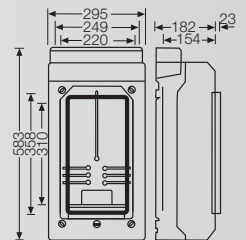

**KV 9339**

**Use in unmetered area after consultation with local power supply companies**  
**degree of protection: IP 65**

- with KWH meter support and meter fastening screws for meters with three-point mounting
- max. installation depth: 162 mm
- with additional DIN rail
- length of DIN rail 172 mm
- with transparent lid
- fasteners for tool operation
- sealable
- with cable entry cover
- cable entry via integrated elastic membranes

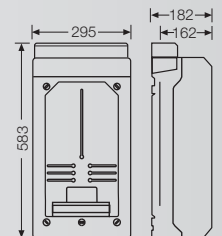



Press-in connecting glands,	168
Threaded connecting glands	168
Mounting plates	168
DIN rails	169
Cable retention	169
Terminals	170 - 171
Labelling system	172
Cable entry covers	172
Locking device	173
Spare keys	173
Facilities for sealing	173
Blanking strip	173



**EVS 16**

**Press-in connecting glands**



- degree of protection: IP 54
- for lateral box assembly of KV and KG boxes
- cable feedthrough for Ø up to 19 mm
- for bore-hole Pg 16, Ø 23 mm

length	15 mm
--------	-------



**AVS 16**

**Threaded connecting glands**



- degree of protection: IP 65
- for lateral box assembly of KV and KG boxes
- cable feedthrough for Ø up to 15 mm
- for bore-hole Pg 16, Ø 23 mm

length	21,5 mm
--------	---------



**KG MP 01**

**Mounting plate for KG 9001**

- material laminated paper, coated
- material thickness 4 mm
- with fixing screws

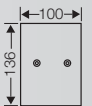

**KG MP 02**

**Mounting plate for KG 9002**

- material laminated paper, coated
- material thickness 4 mm
- with fixing screws

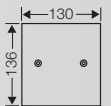

**KG MP 03**

**Mounting plate for KG 9003**

- material laminated paper, coated
- material thickness 4 mm
- with fixing screws

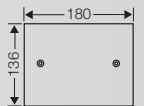



**KG TS 01**

**DIN rail for KG 9001**

- in accordance with DIN EN 60 715
- for equipment or terminals with clip-on mounting
- with fixing screws

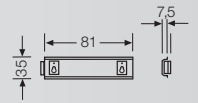

**KG TS 02**

**DIN rail for KG 9002**

- in accordance with DIN EN 60 715
- for equipment or terminals with clip-on mounting
- with fixing screws

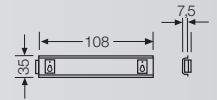

**KG TS 03**

**DIN rail for KG 9003**

- in accordance with DIN EN 60 715
- for equipment or terminals with clip-on mounting
- with fixing screws

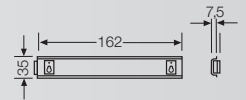

**KHR 01**

**Cable retention  
for cable diameter 6,5 - 14 mm**

- set with 10 x 6 cable retention rings
- 30 pieces for cable diameter 6,5 - 10 mm
- 30 pieces for cable diameter 10 - 14 mm



**KHR 02**

**Cable retention  
for cable diameter 10 - 16 mm**

- set with 10 x 6 cable retention rings
- 30 pieces for cable diameter 10 - 14 mm
- 30 pieces for cable diameter 13 - 16 mm

**KV FC 03**

**PE and N terminal  
per PE/N 1 x 25 mm<sup>2</sup>, 4 x 4 mm<sup>2</sup> Cu**

- for small-type distribution boards with 3 modules
- FIXCONNECT® plug-in terminal technology, for terminal technology refer to technical data

rated insulation voltage	AC 400 V
--------------------------	----------

**KV FC 04**

**PE and N terminal  
per PE/N 2 x 25 mm<sup>2</sup>, 4 x 4 mm<sup>2</sup>, Cu**

- for small-type distribution boards with 4.5 modules
- FIXCONNECT® plug-in terminal technology, for terminal technology refer to technical data

rated insulation voltage	AC 400 V
--------------------------	----------

**KV FC 06**

**PE and N terminal  
per PE/N 2 x 25 mm<sup>2</sup>, 4 x 4 mm<sup>2</sup>, Cu**

- for small-type distribution boards with 6 modules
- FIXCONNECT® plug-in terminal technology, for terminal technology refer to technical data

rated insulation voltage	AC 400 V
--------------------------	----------

**KV FC 09**

**PE and N terminal  
PE/N 2 x 25 mm<sup>2</sup>, 8 x 4 mm<sup>2</sup>, Cu each**

- for small-type distribution boards with 9 modules
- FIXCONNECT® plug-in terminal technology, for terminal technology refer to technical data

rated insulation voltage	AC 400 V
--------------------------	----------

**KV FC 12**

**PE and N terminal  
per PE/N 3 x 25 mm<sup>2</sup>, 12 x 4 mm<sup>2</sup>, Cu**

- for small-type distribution boards with 12 modules and KV empty boxes
- FIXCONNECT® plug-in terminal technology, for terminal technology refer to technical data
- N separable for various potentials

rated insulation voltage	AC 400 V
--------------------------	----------

**KV FC 18**

**PE and N terminal  
per PE/N 4 x 25 mm<sup>2</sup>, 16 x 4 mm<sup>2</sup>, Cu**

- for small-type distribution boards with 18 modules per row
- FIXCONNECT® plug-in terminal technology, for terminal technology refer to technical data
- N separable for various potentials

rated insulation voltage	AC 400 V
--------------------------	----------



## KV FC 24

**PE and N terminal**  
per PE/N 6 x 25 mm<sup>2</sup>, 24 x 4 mm<sup>2</sup>, Cu

- for small-type distribution boards with 12 modules and KV empty boxes
- FIXCONNECT® plug-in terminal technology, for terminal technology refer to technical data
- N separable for various potentials

rated insulation voltage	AC 400 V
--------------------------	----------



## KV FC 36

**PE and N terminal**  
per PE/N 8 x 25 mm<sup>2</sup>, 32 x 4 mm<sup>2</sup>, Cu

- for small-type distribution boards with 18 modules per row
- FIXCONNECT® plug-in terminal technology, for terminal technology refer to technical data
- N separable for various potentials

rated insulation voltage	AC 400 V
--------------------------	----------



## KG PN 01

**PE and N terminal**

- for KG 9001
- per PE/N number x cross section 3 x 25 mm<sup>2</sup>, 3 x 4 mm<sup>2</sup> Cu, screw-type terminal

rated insulation voltage	AC 400 V
--------------------------	----------



## KG PN 02

**PE and N terminal**

- for KG 9002
- PE+N x cross section 3 x 25 mm<sup>2</sup>, 5 x 4 mm<sup>2</sup> Cu, screw-type terminal

rated insulation voltage	AC 400 V
--------------------------	----------



## KG PN 03

**PE and N terminal**

- for KG 9003
- per PE/N number x cross section 4 x 25 mm<sup>2</sup>, 7 x 4 mm<sup>2</sup> Cu, screw-type terminal

rated insulation voltage	AC 400 V
--------------------------	----------



### FC BS 5

#### FIXCONNECT labelling system set with 5 pieces

- labelling system for FIXCONNECT plug-in terminals, not for terminals 2x25 / 4x4 mm<sup>2</sup>
- for attaching of labelling strips or marking with felt tip pen



### FC BS 6

#### FIXCONNECT labelling system

- labelling system for FIXCONNECT plug-in terminals, for terminals 2x25 / 4x4 mm<sup>2</sup>
- for attaching of labelling strips or marking with felt tip pen
- set with 5 pieces



### KV EB 03

#### Cable entry cover

- for small-type distribution boards with 3 modules
- for replacement purposes (1 cable entry cover included with supply of the board)

RAL  
7035



### KV EB 04

#### Cable entry cover

- for small-type distribution boards with 4.5 modules
- for replacement purposes (1 cable entry cover included with supply of the board)

RAL  
7035



### KV EB 06

#### Cable entry cover

- for small-type distribution boards with 6 modules
- for replacement purposes (1 cable entry cover included with supply of the board)

RAL  
7035



### KV EB 09

#### Cable entry cover

- for small-type distribution boards with 9 modules
- and for KV 9325, KV 9363
- for replacement purposes (1 cable entry cover included with supply of the board)

RAL  
7035



### KV EB 12

#### Cable entry cover

- for small-type distribution boards with 12 modules per row
- only order additionally if the cable entry should be covered at the top and bottom (1 cable entry cover included with supply of the board)

RAL  
7035



### KV EB 18

#### Cable entry cover

- for small-type distribution boards with 18 modules per row
- only order additionally if the cable entry should be covered at the top and bottom (1 cable entry cover included with supply of the board)

RAL  
7035



**KV ES 1**

**Locking device  
for small-type distribution boards 12 - 54  
modules**

- profile cylinder with 2 keys



**KV ES 2**

**Spare key**

- for door lock KV ES 1 or KV ES 3
- 2 pieces



**KV ES 3**

**Locking device  
for small-type distribution boards 3 - 9  
modules**

- and for KV 9325, KV 9363
- profile cylinder with 2 keys



**KV PL 2**

**Facility for sealing  
for small-type distribution boards 12 - 54  
modules**

- for sealing the top and bottom parts of the box (doors can be sealed without accessories)



**KV PL 3**

**Facility for sealing  
for small-type distribution boards 3 - 9  
modules**

- and for KV 9325, KV 9363
- for sealing the top and bottom parts of the box (doors can be sealed without accessories)



**AS 12**

**Blanking strip  
12 modules**

- 12 x 18 mm, divisible every 9 mm
- for the covering of spare equipment openings, for material thickness up to 3 mm



**AS 18**

**Blanking strip  
18 modules**

- 18 X 18 mm, divisible every 9 mm
- for the covering of spare equipment openings, for material thickness up to 3 mm





Detail Dimensions in mm	175
Mounting Dimensions in mm	176
Box Assembly	177
Terminals	178 - 179
Standards	180
Operating and Ambient Conditions	181

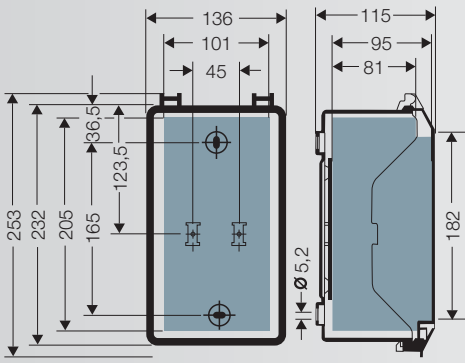

KG 9001  
 KG 9001 IN

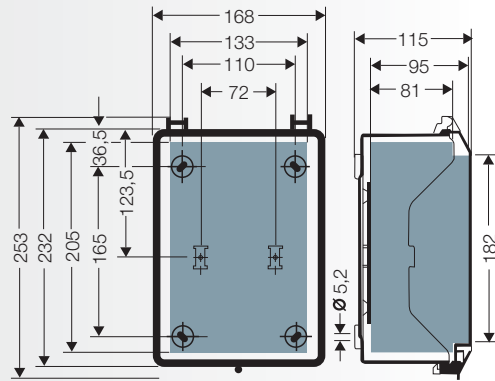

KG 9002  
 KG 9002 IN

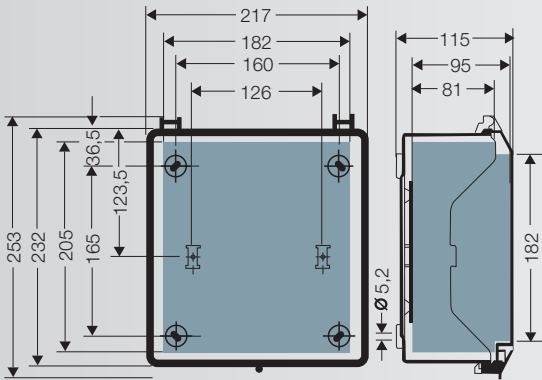

KG 9003  
 KG 9003 IN

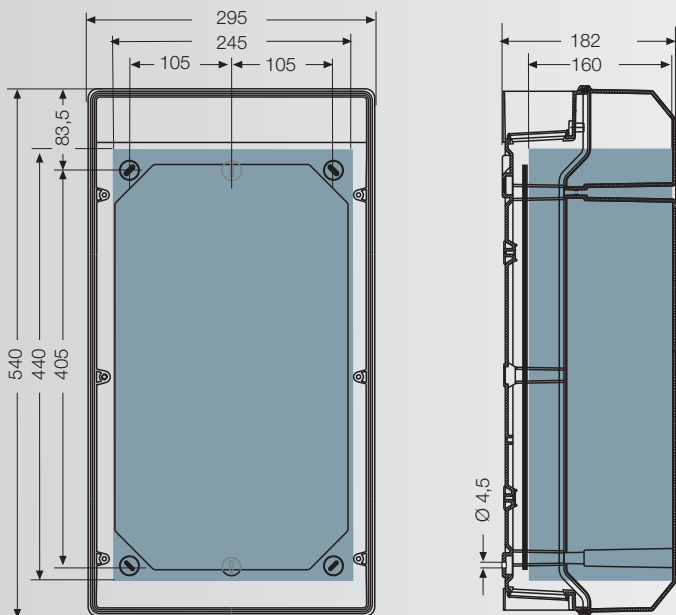

KV 9331

usable installation space  
 which mounted cable glands

Wall mounting for screws up to 4.5 mm diameter.

Circuit breaker boxes  
3 modules

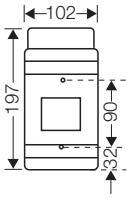

Circuit breaker boxes  
4.5 modules

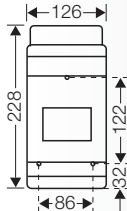

Circuit breaker boxes  
6 modules

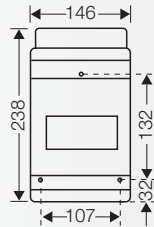

Circuit breaker boxes  
9 modules

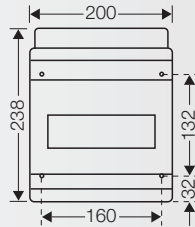

Circuit breaker boxes  
12 modules

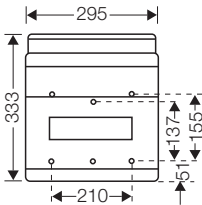

Circuit breaker boxes  
2 x 12 modules

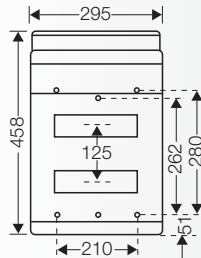

Circuit breaker boxes  
3 x 12 modules

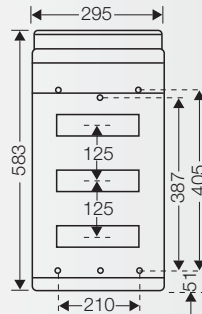

Circuit breaker boxes  
4 x 12 modules

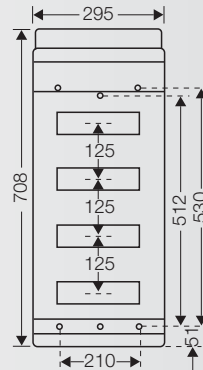

Circuit breaker boxes  
1 x 18 modules

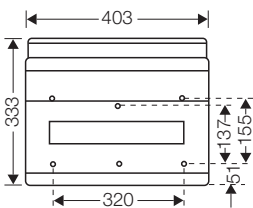

Circuit breaker boxes  
2 x 18 modules

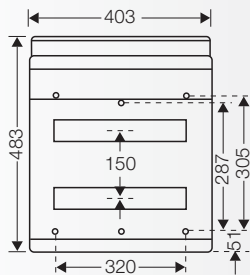

Circuit breaker boxes  
3 x 18 modules

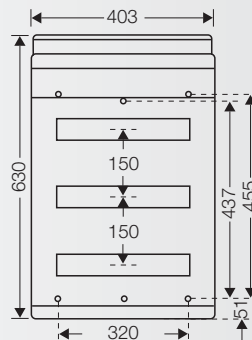

By turning the rail by 180°, the assembly depth under the protection cover can be increased to 59 mm. No additional components are required.

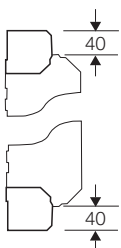

Cable entry cover for KV Circuit breaker boxes IP 54 and IP 65 with 12-54 modules mounted on top and the bottom.

## Technical Details Box Assembly

### KV Circuit breaker boxes can be assembled laterally as shown below:

- in degree of protection IP 65 with threaded connecting glands AVS 16
- in degree of protection IP 54 with press-in connecting glands EVS 16

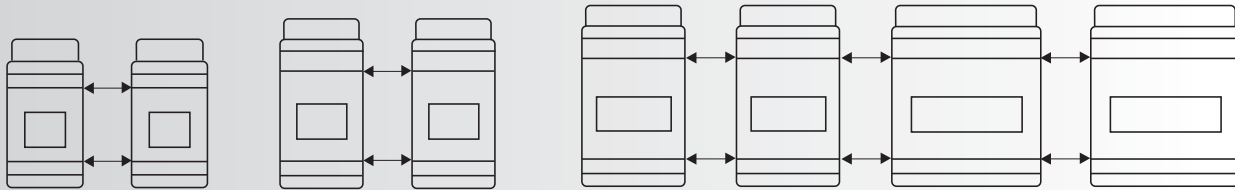

KV Circuit breaker boxes 3 modules    KV Circuit breaker boxes 4.5 modules    KV Circuit breaker boxes 6 modules    KV Circuit breaker boxes 9 modules

### KV Circuit breaker / Meter and Empty boxes can be assembled laterally as shown below:

- in degree of protection IP 65 with threaded connecting glands AVS 16
- in degree of protection IP 54 with press-in connecting glands EVS 16

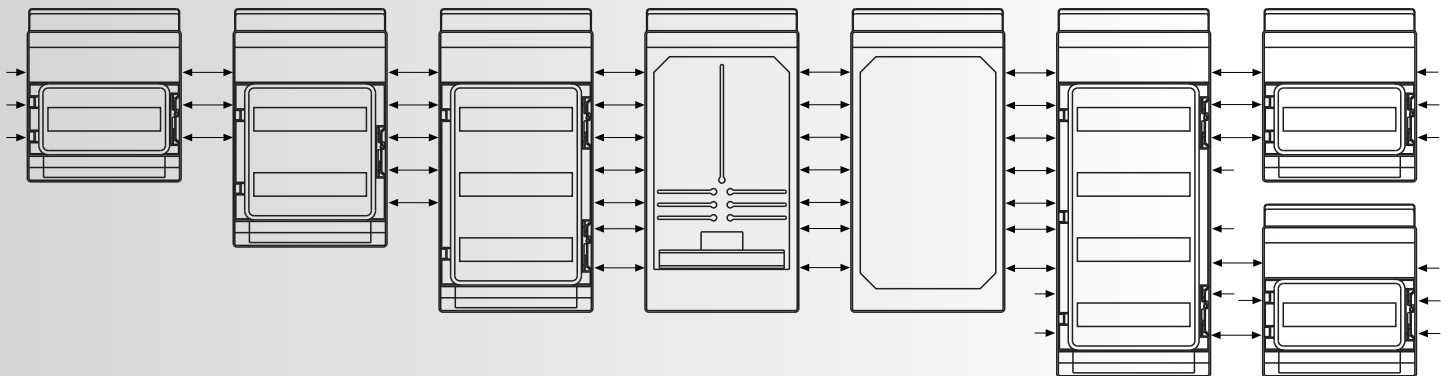

KV circuit breaker boxes 12 modules    KV circuit breaker boxes 2x12 modules, KV 9220, KV 9220 M    KV circuit breaker boxes 3x12 modules, KV 9330, KV 9330 M    KWH Meter boxes KV 9338, KV 9337    KV 9331    KV empty box 4x12 modules KV 9440, KV 9440 M    KV circuit breaker boxes 12 modules

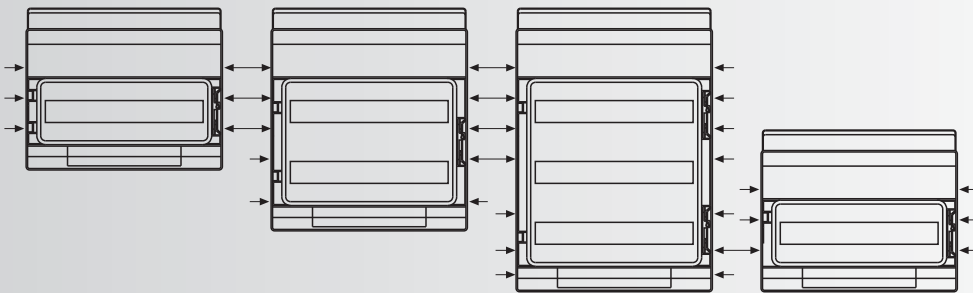

KV circuit breaker boxes 18 modules    KV circuit breaker boxes 2 x 18 modules, KV 9230, KV 9230 M    KV circuit breaker boxes 3 x 18 modules, KV 9350, KV 9350 M    KV circuit breaker boxes 18 modules

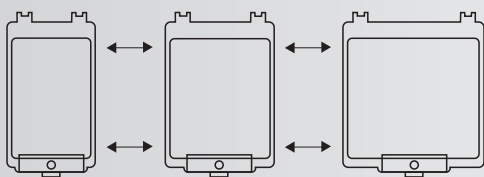

KG 9001    KG 9002    KG 9003  
KG 9001 IN    KG 9001 IN    KG 9001 IN

**PE and N FIXCONNECT® terminal**

**Rated connecting capacity of PE and N terminals**

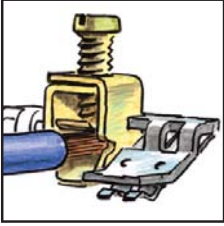
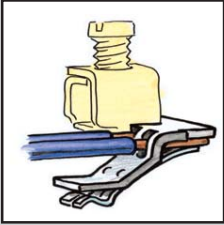
Clamping unit	Corresponding cross-sections/copper				
	max. number	from - to max.	max. number	from - to max.	
Screw-type terminal 25 mm <sup>2</sup> 	1 1 1 3 3 4 4	25 mm <sup>2</sup> , s 16 mm <sup>2</sup> , s 10 mm <sup>2</sup> , sol 6 mm <sup>2</sup> , sol 4 mm <sup>2</sup> , sol 2.5 mm <sup>2</sup> , sol 1.5 mm <sup>2</sup> , sol	} Tested as connecting terminal for several conductors of the same cross-sections for using in one circuit	1 1 1 1 1 1 1	25 mm <sup>2</sup> , f 16 mm <sup>2</sup> , f 10 mm <sup>2</sup> , f 6 mm <sup>2</sup> , f 4 mm <sup>2</sup> , f 2.5 mm <sup>2</sup> , f 1.5 mm <sup>2</sup> , f
Plug-in terminal 4 mm <sup>2</sup> 	1	1.5 - 4 mm <sup>2</sup> , sol		1	1.5 - 4 mm <sup>2</sup> , f  <small>Without end ferrule; clamping unit has to be opened with a tool when conductor is inserted</small>

**Current carrying capacity of the connecting device: 80 A**

All terminals are secured against self loosening.

#### Terminal equipment and number of conductors to be connected

##### PE terminal for copper conductors

Number of modules	PE terminal	
	up to 4 mm <sup>2</sup>	up to 25 mm <sup>2</sup>
3	4x4 mm <sup>2</sup>	1x25 mm <sup>2</sup>
4.5 6	4x4 mm <sup>2</sup>	2x25 mm <sup>2</sup>
9	8x4 mm <sup>2</sup>	2x25 mm <sup>2</sup>
12	12x4 mm <sup>2</sup>	2x25 mm <sup>2</sup>
18	16x4 mm <sup>2</sup>	4x25 mm <sup>2</sup>
24 36 (3-row) 48	24x4 mm <sup>2</sup>	6x25 mm <sup>2</sup>
36 (2-row) 54	32x4 mm <sup>2</sup>	8x25 mm <sup>2</sup>

##### N terminal for copper conductors

Number of modules	N terminal		
	up to 4 mm <sup>2</sup>	up to 25 mm <sup>2</sup>	plug-in jumper
3	4x4 mm <sup>2</sup>	1x25 mm <sup>2</sup>	
4.5 6	4x4 mm <sup>2</sup>	2x25 mm <sup>2</sup>	
9	8x4 mm <sup>2</sup>	2x25 mm <sup>2</sup>	
12	12x4 mm <sup>2</sup>	2x25 mm <sup>2</sup>	
18	16x4 mm <sup>2</sup>	4x25 mm <sup>2</sup>	
24 36 (3-row) 48	24x4 mm <sup>2</sup>	6x25 mm <sup>2</sup>	
36 (2-row) 54	32x4 mm <sup>2</sup>	8x25 mm <sup>2</sup>	

**KV circuit breaker boxes comply with the following standards and regulations:**

- IEC 60 439-3, EN 60 439-3,  
...low voltage switchgear and controlgear assemblies intended to be in places  
where unskilled persons have access to their use - distribution boards
- IEC 60 999, Connecting devices  
Safety requirements for screw-type and screwless-type clamping units for electrical copper conductors
- EN 60 529 / DIN VDE 0470 Teil 1  
Degrees of protection provided by enclosures (IP-Code)

	KV Smalltype distribution boards PS polystyrene			KV PC Smalltype distribution boards PC polycarbonate	
	KV Small-type distribution boards and KWH Meter boxes	Empty boxes	Cable entry ESM ..., EVS 16	KV PC Small-type distribution boards	Threaded connecting glands AVS 16
<b>Application area</b>	<b>IP 54/65:</b> Suitable for indoor installation (normal environment and/or protected outdoor) according to DIN VDE 0100 Teil 737			The enclosures are suitable for outdoor installation - harsh environment and / or outdoor. The material is examined for UV resistance by the institute for plastics and thereby suitable for the outdoor installation during UV effect. However the climatic influences and effects on the equipment are to be considered.	
<b>Ambient temperature</b>					
- Average value over 24 hours	+ 35° C	–	+ 35° C	+ 35° C	+ 55° C
- Maximum value	+ 40° C	+ 60° C	+ 40° C	+ 40° C	+ 70° C
- Minimum value	– 5° C	– 25° C	– 25° C	– 5° C	– 40° C
<b>Relative humidity</b>					
- short-time	50% at 40° C 100% at 25° C	–	–	–	–
<b>Fire protection</b> in the case of internal faults	Demands placed on electrical devices from standards and laws:  Minimum requirements - Glow wire test in accordance with IEC 60 695-2-11: - 650° C for boxes and cable glands - 850° C for parts of insulating material necessary to retain current carrying parts in position				
<b>Burning behaviour</b>					
- Glow wire test IEC 60 695-2-11	750° C	750° C	750° C	960° C	750° C
- UL Subject 94	V-2 flame-retardant self-extinguishing	V-2 flame-retardant self-extinguishing	– flame-retardant self-extinguishing	V-2 flame-retardant self-extinguishing	V-2 flame-retardant self-extinguishing
<b>Degree of protection against mechanical load</b>	IK08 (5 Joule)	IK08 (5 Joule)	–	IK08 (5 Joule)	–
<b>Toxic behaviour</b>	halogen-free silicone-free	halogen-free silicone-free	halogen-free silicone-free	halogen-free silicone-free	halogen-free silicone-free
	<b>“Halogen-free” in accordance with IEC 754-2 “Common test methods for cables - Determination of the amount of halogen acid gas”.</b>  <b>For material properties see technical data.</b>				

