



**Product information** as at: 9/2010

**Safe product solutions  
conforming to standards for  
Photovoltaic plants  
ON-grid systems**

- PV Generator junction boxes
  - Solar inverter collectors
- NEW:**
- PV Generator junction boxes with string overload protection or blocking diodes

# Solar powered by Hensel

The photovoltaic market is going to grow significantly in coming years as more and more investors and home owners are betting on solar power's high margin electricity. With our ENYSUN distribution board systems for photovoltaic plants conforming to standards, we support you in accessing this market. ENYSUN is a high value, modular system, which generates additional sales potential for you on the growing photovoltaic market.

Profit from a system which offers you clear competitive advantages on the market and which you can always rely on.

## ENYSUN

Professional photovoltaic distribution board



### Hensel is the market leader in innovative products and services for electrotechnical building facility.

Founded in 1931, Hensel is now part of an international group of companies doing business around the world. It has its headquarters in Lennestadt, Germany and subsidiaries in the most important international markets to provide an international presence and assure that the company is never far away.

Successfully mastering the future means cooperation in dialog for Hensel. The exchange with market partners and the consistent focus on practical challenges is a transfer that provides valuable inspiration for further development of products and services.

Where environmental influences, dust and

moisture demand particularly demanding installation technology, Hensel enables safe energy distribution with innovative solutions. The program of modern installation and distribution systems for national and international applications have made HENSEL a market leader in tapping, fusing and distributing electrical energy in the low voltage sector.

Hensel guarantees its customers continually high standard of quality with decades of production expertise and a quality management system strictly in adherence with the DIN EN ISO 9001-2008 standard at all its factories.





## Photovoltaic solutions from Hensel

### Standardised and pre-fabricated

■ Our ENYSUN product solutions provide a number of advantages when selecting and installing photovoltaic systems. The distributors are prefabricated making them quick and easy to connect. The PV generator junction boxes and solar inverter collectors are equipped with busbars, protection devices and terminals, so that you only have to wire on site. Thus you save time and costs with procurement and installation.

### Proven and tested Hensel quality

■ All ENYSUN distribution system products fulfill the IEC 60 364-712 standard. The general fulfilment of this standard demonstrates Hensel ENYSUN product series' high quality. Using high quality materials means that you can always count on them functioning perfectly. ENYSUN distributors are totally insulated , impact resistant, dust proof and water-proof (degree of protection IP 65), UV resistant and resistant to corrosion from rain, ice and snow.

### Cable entry and ventilation

■ The formation of condensation water in closed boxes cannot be prevented in outdoor applications! Combi climate glands in boxes with a high degree of protection prevent accumulations of condensation resulting from large temperature fluctuations caused by changing weather, intense solar radiation etc.

### Your advantage:

Cable entry and ventilation in one.

1

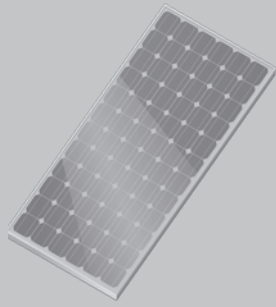

PV generators

2



PV generator junction boxes

3



Solar inverter

4



PV Solar inverter collector

5



Disconnection, metering, overcurrent protection device

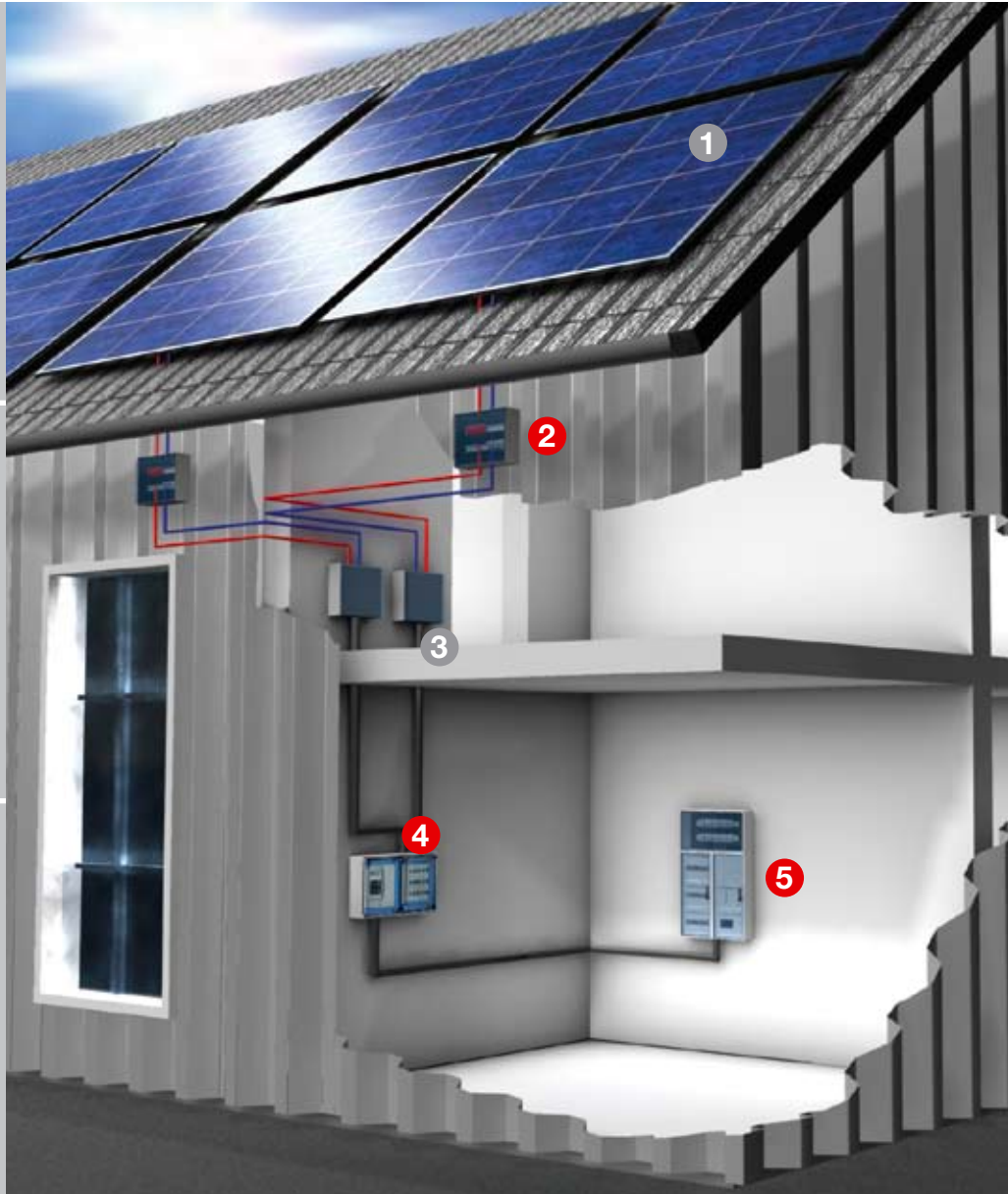

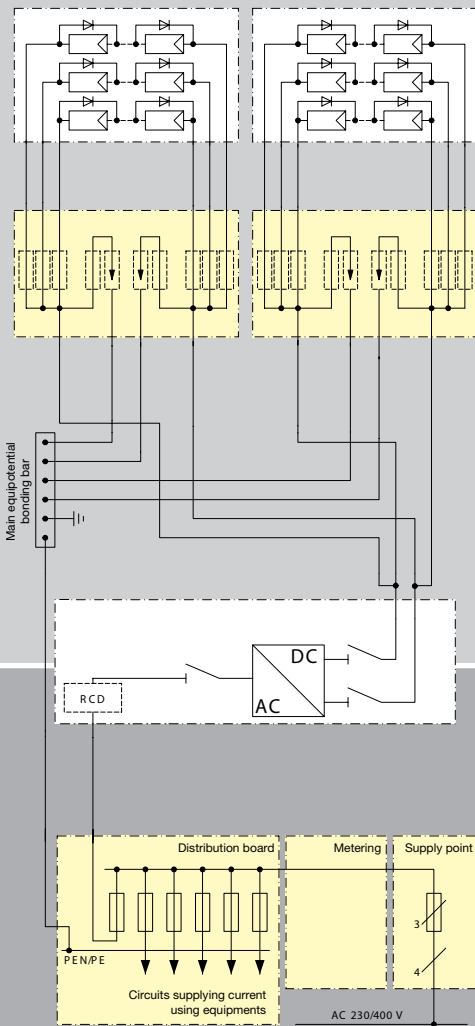

Up to DC 1000 V

AC 230/400 V

## What does the IEC 60 364-712 standard require when setting up photovoltaic (PV) power supply systems?

### Equipment standards

712.511.1 PV modules shall comply with the requirements of the relevant equipment standard, e.g. IEC 61215 for crystalline PV modules. PV modules of class II construction or with equivalent insulation are recommended if  $U_{OC\ STC}^{1)}$  of the PV strings exceeds 120 V DC.

The PV array junction box, PV generator junction box and switchgear assemblies shall be in compliance with IEC 60439-1.

712.536.2.2.5.1 All junction boxes (PV generator and PV array boxes) shall carry a warning label indicating that active parts inside the boxes may still be live after isolation from the PV inverter.

### Protection measures

#### 712.312.2 Types of system earthing

Earthing of one of the live conductors of the DC side is permitted, if there is at least simple separation<sup>2)</sup> between the AC side and the DC side.

#### NOTE

Any connections with earth on the DC side should be electrically connected so as to avoid corrosion.

712.413.2 Protection by use of **class II** or equivalent insulation should preferably be adopted on the DC side.

### Wiring

712.522.8.1 PV string cables, PV array cables and PV DC main cables shall be selected and erected so as to minimize the risk of earth faults and short-circuits.

NOTE This may be achieved for example by reinforcing the protection of the wiring against external influences by the use of single-core sheathed cables.

712.433.1 Overload protection may be omitted to PV string and PV array cables when the continuous current-carrying capacity of the cable is equal to or greater than 1,25 times  $I_{SC\ STC}^{3)}$  at any location.

712.433.2 Overload protection may be omitted to the PV main cable if the continuous current-carrying capacity is equal to or greater than 1,25 times  $I_{SC\ STC}^{3)}$  of the PV generator.

NOTE The requirements of 712.433.1 and 712.433.2 are only relevant for protection of the cables. See as well the manufacturer's instructions for protection of PV modules.

712.444.4.4 To minimize voltages induced by lightning, the area of all wiring loops shall be as small as possible.

<sup>1)</sup>  $U_{OC\ STC}$  = no-load voltage under standard testing conditions

<sup>2)</sup> Simple disconnect = disconnect between two circuits or between a circuit and an earthing using basic insulation

<sup>3)</sup>  $I_{SC\ STC}$  = Short circuit current under standard testing conditions

**System description  
Enclosure system**

	<b>Ambient conditions</b>	<p>Ambient temperature</p> <ul style="list-style-type: none"> <li>■ for empty enclosures: - 25°C up to + 70° C</li> <li>■ for distribution boards <sup>1)</sup> according to IEC 60 439: - 5°C up to + 35° C, max. + 40° C</li> </ul> <p>Relative humidity: 50% at 40° C, 100% at 25° C</p> <p><sup>1)</sup> The ambient temperature for distribution boards is reduced by the installed equipment technology!</p>
	<b>Application area</b>	<p><b>The enclosures are suitable for the outdoor installation - harsh environment and / or outdoor.</b></p> <p>However the climatic influences and effects on the equipment are to be considered.</p>
	<b>Insulation</b>	<p>Insulated enclosures <b>(Protection class II)</b> </p>
	<b>Impact strength</b>	<p>Degree of protection against mechanical load IK 08 (5 Joule) in accordance with IEC 62 262</p>
	<b>Protection against foreign solid objects and direct contact</b>	<p>Dust-proof Degree of protection IP <b>65</b></p>
	<b>Protection against ingress of water with harmful effects</b>	<p>Protected against water jets Degree of protection IP <b>65</b></p>
	<b>Electrical parameters</b>	<p>Rated current: 630 A Rated insulation voltage: AC 690 V, <b>DC 1000 V*</b>, IEC 60 664 * the rated insulation voltage is possibly reduced by the installed equipment technology</p>

**Material:** Thermoplastic

	<b>Burning behaviour</b>	<p>Glow wire test 960°C in accordance with IEC 60 695-2-11 flame-retardant, self-extinguishing</p>
	<b>UV resistance</b>	<p>The Material is examined and therefore qualified for outdoor installation (harsh environment and / or outdoor) during direct sun radiation</p>
	<b>Chemical resistance</b>	<p>Resistance against acid 10% and lye 10%, petrol and mineral oil</p>
	<b>Toxic behaviour</b>	<p>Silicone- and halogen-free</p>
	<b>Resistance to corrosion</b>	<p>Resistant against weather-related demand such as rains, ice and snow.</p>

Dependent on the system

Dependent on material



The boxes are suitable for outdoor installation. The materials used in Mi System enclosures are generally UV resistant meaning that the mechanical stability shall remain after UV exposure.

Direct solar radiation as well as power dissipation within a box can overheat the interior of the box. Exterior temperatures that are too low e.g. under  $-5^{\circ}\text{C}$  can also influence the functioning of the equipment. Therefore climatic influence on the equipment needs to be taken into consideration.

The top of the box should be protected with a cover to protect against damage created by weather conditions such as rain, ice and snow.

Possible impact from chemical influences also needs to be taken into consideration when selecting an installation location, as well as IP degree of protection and climate impact.

Additional measures might be necessary such as ventilation (note degree of protection) to assure that the maximum ambient temperature allowed is not exceeded for the installed equipment as well as to prevent condensation from forming. Hensel combi climate glands (KBM) can be used in outdoor installations for cable entries and ventilation as well (see accessories).

**Formation of condensed water in enclosures**

**How does condensed water occur in enclosures with a high degree of protection?**

The internal temperature is higher than the external temperature due to the power dissipation of the built-in devices.

The warm air inside the enclosure attempts to accumulate moisture. This enters from outside through the seal as the enclosures are not gas-tight.

The internal temperature is reduced by cooling down the system e.g. by switching off the loads. The cooler air emits moisture which is collected as condensed water on the cooling inner surfaces.

**In which areas does condensed water occur?**

**Formation of condensed water and retaliatory actions**

The problem of condensed water forming only occurs in enclosures with a high degree of protection  $\geq \text{IP } 54$  since the temperature adjustment that is carried out from inside to outside is too low due to the high density of the enclosure and its material.

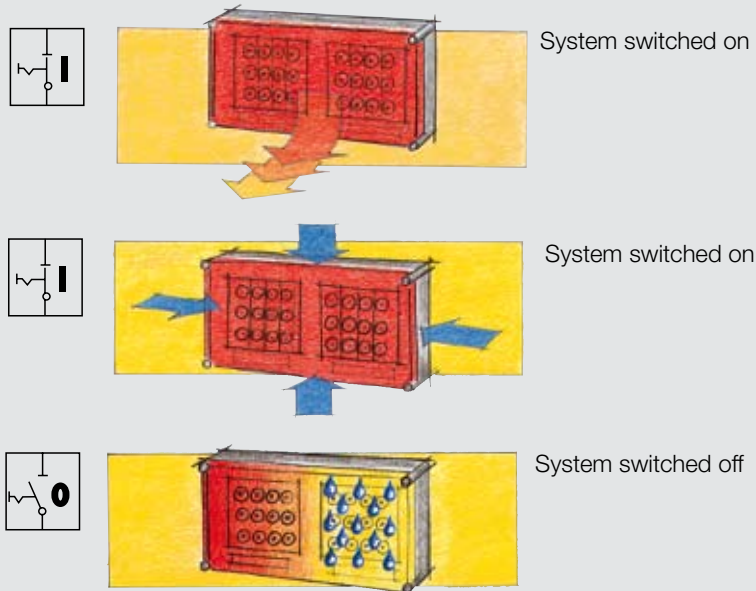

**Formation of condensed water for indoor installations:**

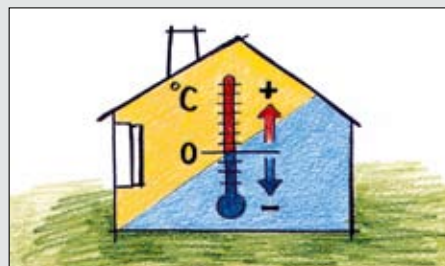

In areas where high levels of air humidity and large temperature fluctuations are expected e.g. in laundry rooms, kitchens, car washes etc.

**Formation of condensed water in protected outdoor installations (protected against weather influences) or unprotected outdoor installations:**



Here condensed water can be formed dependent on the weather, high air humidity, direct sunlight and temperature differences compared to the wall



**Ambient conditions:**

Degree of protection: IP 65  
Stainless steel external brackets, optional: Combi climate glands to reduce condensation formation in outdoor installations, order separately, see accessories.

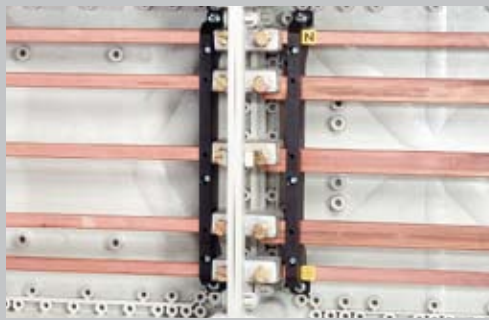

### EMC compliant busbar

The busbar system comes standard with N/PEN conductors in the phase conductor area. The N busbars have the same current carrying capacity as the phase conductor. These busbars are appropriate for:

- Harmonics created by the solar inverter.
- Unbalanced loads (Unbalanced load limit 4.6 kVA allowed by power supply companies) created by power supply companies.



### Overvoltage protection

The exposed sequence of photovoltaic generators on roofs or in fields make lightning and overvoltage protection an important part of protecting investments. A direct lightning strike in the PV generator can destroy the module and/or the inverter (primary damage). As photovoltaic (PV) systems are required have a connection to the building's electrical installation, lightning damage to the PV generator could damage the entire plant (secondary damage).

Many liability insurers call upon the **VdS-Merkblatt 2010** directive, the "Risk oriented lightning and surge protection directive to prevent damage," which requires lightning and surge protection for PV systems above 10 kWp.

### Protection measures

In principal it must be assured that no direct lightning strike is possible in the PV generator. The necessary protection can be provided using "isolated lightning protection" products from numerous manufacturers and isolated outgoing cables when necessary. Should an **external lightning protection facility** be available, then a **type 1** lightning current arrester for the AC power supply is to be installed on the building's main distribution board.

Should **no lightning protection** be available then a **type 2** surge arrester should be sufficient under certain circumstances.

### Inverter protection

To protect the inverter, both the DC input and the AC output need to be protected. If the inverter is installed at a distance of **> 5 m** to the building's main distribution board, then a **type 2 for AC wire** overvoltage protection device shall be used to prevent surge damage, e.g. from switching overvoltages from the mains.

**Type 2** surge protection devices are especially designed for string conductors from the **DC inputs**. The monitoring elements need to be specifically designed for direct voltage. Personnel need to be able to safely exchange the protection modules even with insulation faults in the plant.

**It is of the utmost importance to integrate the individual lightning and overvoltage protection concept into the photovoltaic plant protection solution. Lightning and overvoltage protection experts can answer any questions in this area.**



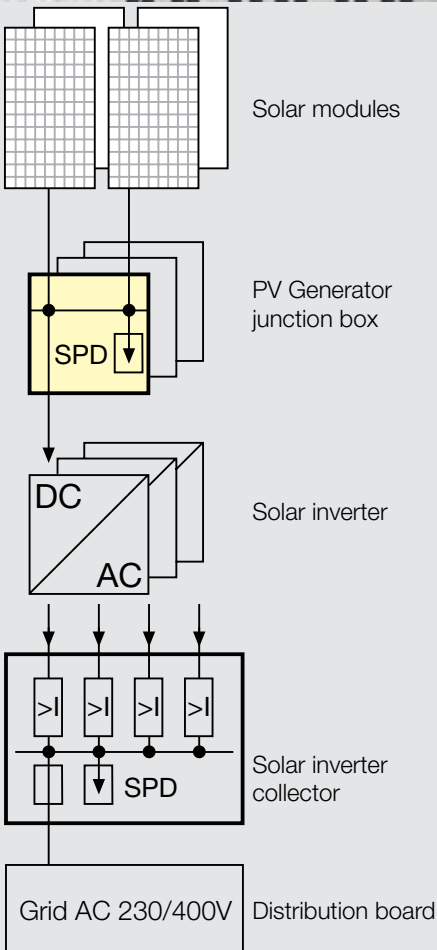

**Connection:**  
Ready for connection with plug-in connectors



**Electrical data:**  
Rated voltage: **DC 1,000 V**  
Rated current: DC 30 A  
Protective measure: **Total insulation** □



**Ambient conditions:**  
UV resistant  
Degree of protection: **IP 65**  
Stainless steel external brackets  
optional: Combi climate glands to reduce condensation formation in outdoor installations.  
(Order separately, see accessories).

# How to choose the correct overload protection for

# PV generator junction boxes:

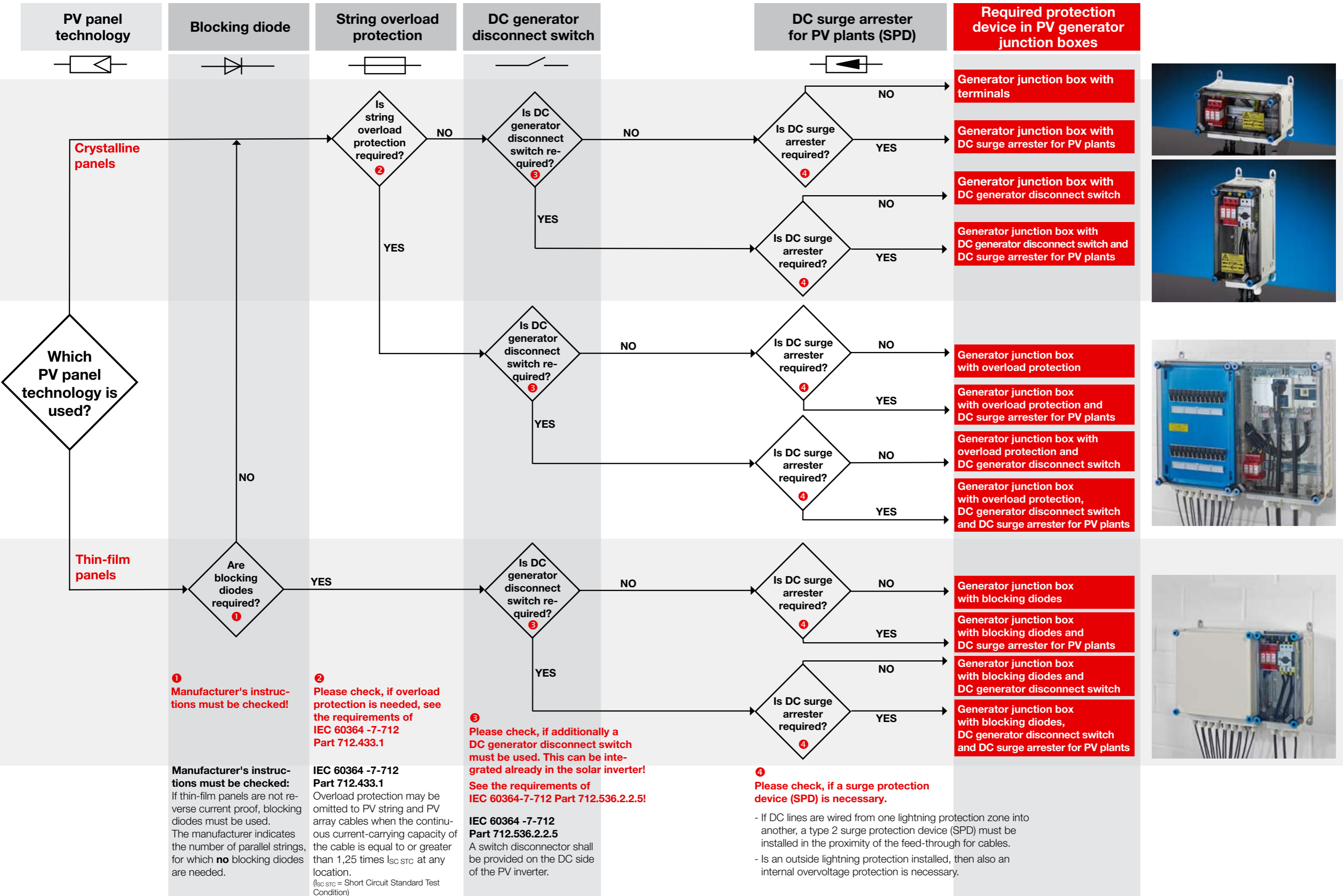

## PV generator junction boxes with surge arrester or DC generator disconnect switch

- current per PV string **DC 30 A max.**
- rated current: DC 1000 V ( $U_{OC,STC}$ )
- protection class: II
- suitable for outdoor installation, UV resistant
- ready for connection
- with stainless steel mounting plate for wall and post installations
- with transparent door
- material: thermoplastic
- colour: grey, RAL 7035
- degree of protection: IP 65



### KV PV 1211 DC Surge arrester

1 x DC type 2 surge arrester  
 rated current: DC 30 A  
 plug-in connectors compatible to MC4  
 1 x PV string on  
 1 x inverter input  
 connection cable length:  
 outgoing cable 2 x 500 mm  
 rated connecting capacity PE:  
 1.5 - 16 mm<sup>2</sup>, copper

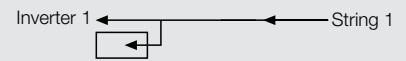
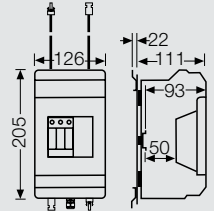

### KV PV 1411 DC/AC Surge arrester

1 x DC type 2 surge arrester  
 rated current: DC 30 A  
 plug-in connectors compatible to MC4  
 1 x PV string on  
 1 x inverter input  
 connection cable length:  
 outgoing cable 2 x 500 mm  
 1 x AC type 2 surge arrester  
 2 terminals per L/N/PE: 6 mm<sup>2</sup>, copper

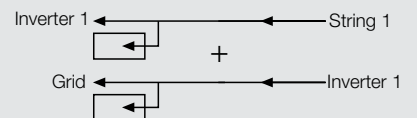
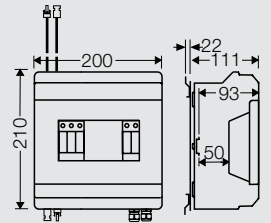

### KV PV 2211 DC Generator disconnect switch

1 x DC generator disconnect switch  
 rated current: DC 30 A  
 \*utilization category: DC-21A  
 plug-in connectors compatible to MC4  
 1 x PV string on  
 1 x inverter input  
 connection cable length:  
 outgoing cable 2 x 500 mm

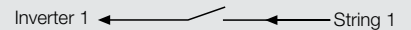
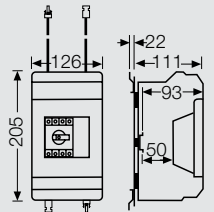

**Customised solutions?  
Contact us!**

**See check list in the appendix!**

\* Utilization category for switch disconnectors:  
 DC-21A = Switching ohmic loads inclusively moderate overload

Installation of KV PV ... generator junction box  
Possible in standard wall and post mounting.



**Post-mounted installation of generator junction box KV PV ... close to the inverter**

Connection to solar inverter only with DC surge arrester

Connection to solar inverter only with DC generator disconnect switch

Connection to solar inverter with combination DC generator disconnect switch and DC surge arrester

Connection to solar inverter with DC and AC surge arrester

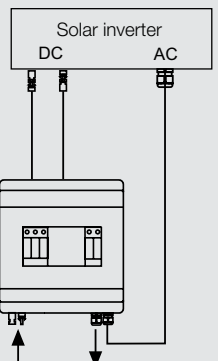
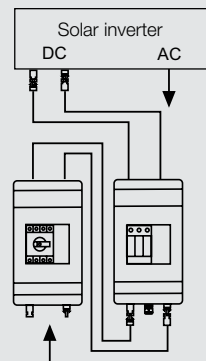
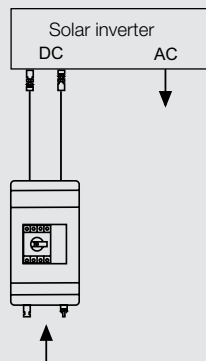
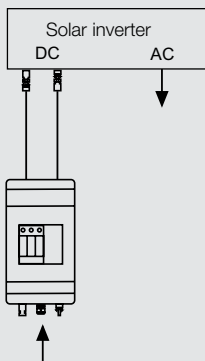

- current per PV string **DC 30 A max.**
- rated current: DC 1000 V ( $U_{OC\ STC}$ )
- protection class: II
- suitable for outdoor installation, UV resistant
- ready for connection
- with stainless steel external brackets
- lid fasteners for tool operation
- material: thermoplastic
- colour: grey, RAL 7032
- degree of protection: IP 65

**Mi PV 1111 1 x PV string on  
1 x inverter input**

1 x DC type 2 surge arrester  
 rated current: DC 30 A  
 plug-in connectors compatible to MC4  
 rated connecting capacity PE:  
 1.5 - 16 mm<sup>2</sup>, copper

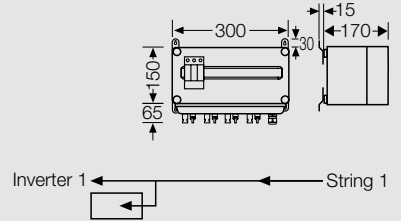
**Mi PV 1122 2 x PV string on  
2 x inverter input**

2 x DC type 2 surge arrester  
 rated current: DC 30 A  
 plug-in connectors compatible to MC4  
 rated connecting capacity PE:  
 1.5 - 16 mm<sup>2</sup>, copper

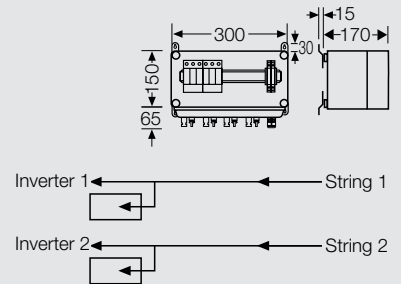
**Mi PV 1133 3 x PV string on  
3 x inverter input**

3 x DC type 2 surge arrester  
 rated current: DC 30 A  
 plug-in connectors compatible to MC4  
 rated connecting capacity PE:  
 1.5 - 16 mm<sup>2</sup>, copper

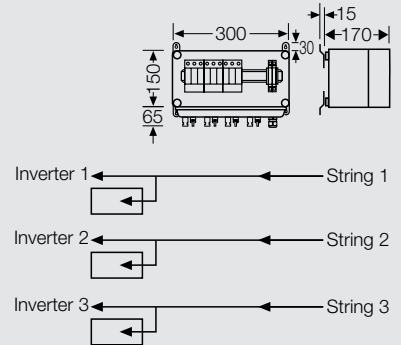

**Customised solutions?  
Contact us!**

**See check list in the appendix!**

- current per PV string **DC 15 A max.**
- rated current: DC 1000 V ( $U_{OC,STC}$ )
- protection class: II
- suitable for outdoor installation, UV resistant
- ready for connection
- with stainless steel external brackets
- lid fasteners for tool operation
- material: thermoplastic
- colour: grey, RAL 7032
- degree of protection: IP 65



**Mi PV 1121 2 x PV string on  
1 x inverter input**

1 x DC type 2 surge arrester  
 rated current: DC 30 A  
 plug-in connectors compatible to MC4  
 rated connecting capacity PE:  
 1.5 - 16 mm<sup>2</sup>, copper

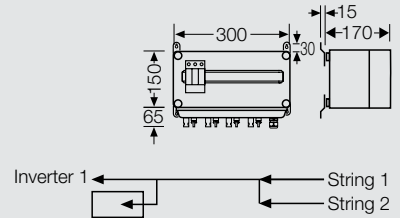

**Mi PV 1242 4 x PV string on  
2 x inverter input**

2 x DC type 2 surge arrester  
 rated current: DC 30 A  
 plug-in connectors compatible to MC4  
 rated connecting capacity PE:  
 1.5 - 16 mm<sup>2</sup>, copper

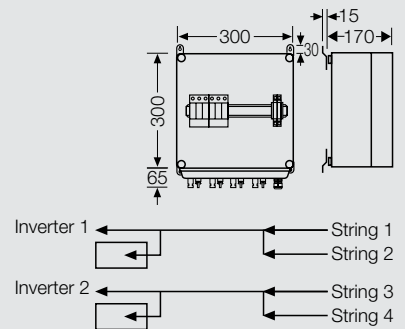

**Mi PV 1263 6 x PV string on  
3 x inverter input**

3 x DC type 2 surge arrester  
 rated current: DC 30 A  
 plug-in connectors compatible to MC4  
 rated connecting capacity PE:  
 1.5 - 16 mm<sup>2</sup>, copper

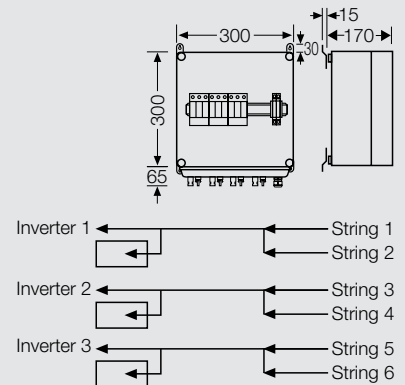

**Customised solutions?  
Contact us!**

See check list in the appendix!

## PV generator junction boxes with surge arrester and DC generator disconnect switch

- current per PV string **DC 30 A max.**
- rated current: DC 1000 V ( $U_{OC\ STC}$ )
- protection class: II
- suitable for outdoor installation, UV resistant
- ready for connection
- with stainless steel external brackets
- lid fasteners for tool operation
- material: thermoplastic
- colour: grey, RAL 7032
- degree of protection: IP 65



### Mi PV 2111 1 x PV string on 1 x inverter input

1 x DC type 2 surge arrester  
1 x DC generator disconnect switch  
rated current: DC 30 A  
\*utilization category: DC-21A  
plug-in connectors compatible to MC4  
rated connecting capacity PE:  
1.5 - 16 mm<sup>2</sup>, copper

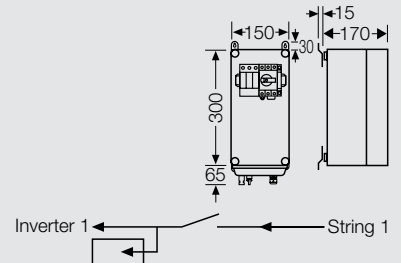

### Mi PV 2222 2 x PV string on 2 x inverter input

2 x DC type 2 surge arrester  
2 x DC generator disconnect switch  
rated current: DC 30 A  
\*utilization category: DC-21A  
plug-in connectors compatible to MC4  
rated connecting capacity PE:  
1.5 - 16 mm<sup>2</sup>, copper

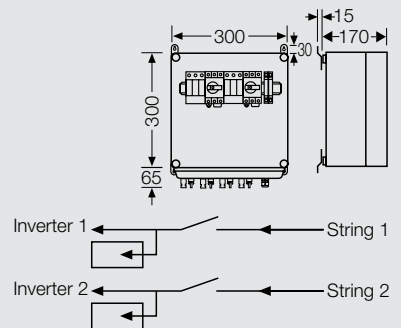

### Mi PV 2233 3 x PV string on 3 x inverter input

3 x DC type 2 surge arrester  
3 x DC generator disconnect switch  
rated current: DC 30 A  
\*utilization category: DC-21A  
plug-in connectors compatible to MC4  
rated connecting capacity PE:  
1.5 - 16 mm<sup>2</sup>, copper

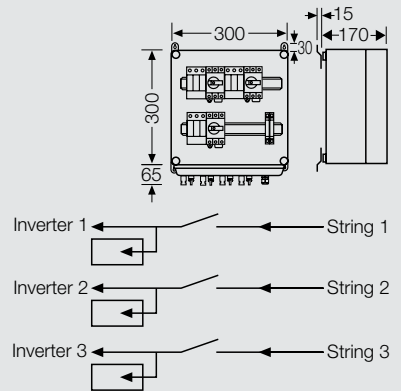

**Customised solutions?  
Contact us!**

**See check list in the appendix!**

\* Utilization category for switch disconnectors:  
DC-21A = Switching ohmic loads inclusively moderate overload

## PV generator junction boxes with surge arrester and DC generator disconnect switch

- current per PV string **DC 15 A max.**
- rated current: DC 1000 V ( $U_{OC\ STC}$ )
- protection class: II
- suitable for outdoor installation, UV resistant
- ready for connection
- with stainless steel external brackets
- lid fasteners for tool operation
- material: thermoplastic
- colour: grey, RAL 7032
- degree of protection: IP 65



### Mi PV 2121 2 x PV string on 1 x inverter input

1 x DC type 2 surge arrester  
1 x DC generator disconnect switch  
rated current: DC 30 A  
\*utilization category: DC-21A  
plug-in connectors compatible to MC4  
rated connecting capacity PE:  
1.5 - 16 mm<sup>2</sup>, copper

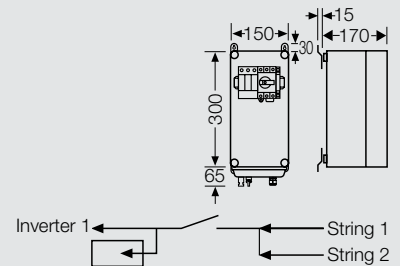

### Mi PV 2242 4 x PV string on 2 x inverter input

2 x DC type 2 surge arrester  
2 x DC generator disconnect switch  
rated current: DC 30 A  
\*utilization category: DC-21A  
plug-in connectors compatible to MC4  
rated connecting capacity PE:  
1.5 - 16 mm<sup>2</sup>, copper

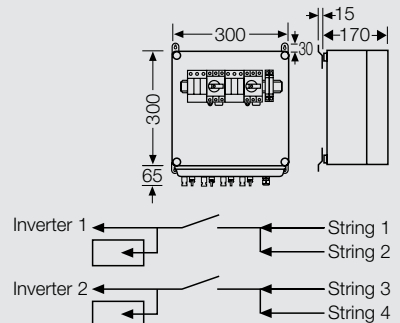

### Mi PV 2263 6 x PV string on 3 x inverter input

3 x DC type 2 surge arrester  
3 x DC generator disconnect switch  
rated current: DC 30 A  
\*utilization category: DC-21A  
plug-in connectors compatible to MC4  
rated connecting capacity PE:  
1.5 - 16 mm<sup>2</sup>, copper

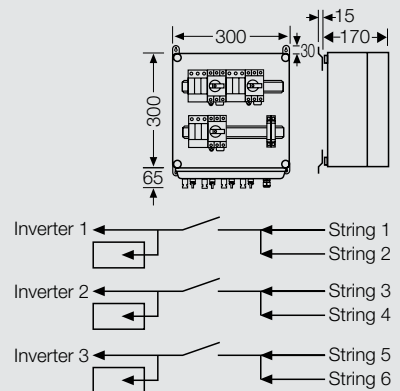

**Customised solutions?  
Contact us!**

**See check list in the appendix!**

\* Utilization category for switch disconnectors:  
DC-21A = Switching ohmic loads inclusively moderate overload

## PV generator junction boxes with string overload protection



- current per PV string **DC 10 A max.**
- rated current: DC 1000 V ( $U_{OC\ STC}$ )
- protection class: II
- suitable for outdoor installation, UV resistant
- ready for connection
- with stainless steel external brackets
- lid fasteners for tool operation
- material: thermoplastic
- colour: grey, RAL 7032
- degree of protection: IP 65



### Mi PV 3611 **12 x PV string on 1 x inverter input** new

12 holder for fuses each + and –  
 connection: 1,5-16 mm<sup>2</sup>  
 1 x DC generator disconnect switch  
 rated current: DC 125 A  
 included cable entry:  
 12 x ASM 16, 12 x ASM 20, 2 x ASM 25

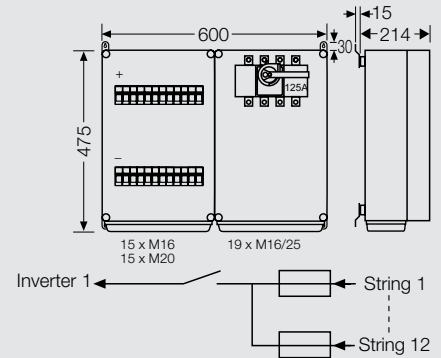

### Mi PV 3621 **12 x PV string on 1 x inverter input** new

12 holder for fuses each + and –  
 connection: 1,5-16 mm<sup>2</sup>  
**1 x DC type 2 surge arrester**  
 rated connecting capacity PE:  
 1,5 - 35 mm<sup>2</sup>, Cu  
 1 x DC generator disconnect switch  
 rated current: DC 125 A  
 included cable entry:  
 12 x ASM 16, 12 x ASM 20, 3 x ASM 25

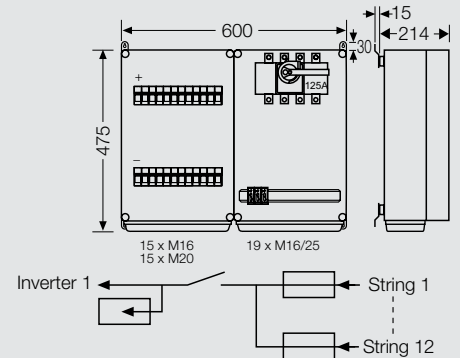

### Mi PV 3931 **24 x PV string on 1 x inverter input** new

24 holder for fuses each + and –  
 connection: 1,5-16 mm<sup>2</sup>  
 1 x DC generator disconnect switch  
 rated current: DC 250 A  
 included cable entry:  
 24 x ASM 16, 24 x ASM 20, 2 x ASM 40

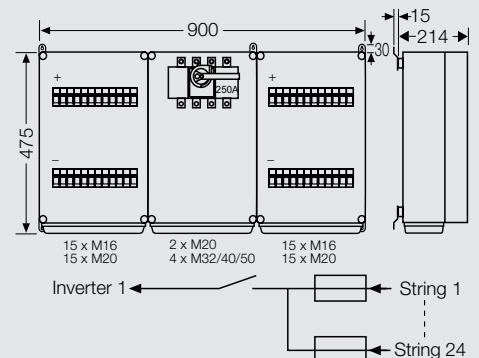

### Mi PV 3941 **24 x PV string on 1 x inverter input** new

24 holder for fuses each + and –  
 connection: 1,5-16 mm<sup>2</sup>  
**1 x DC type 2 surge arrester**  
 rated connecting capacity PE:  
 1,5 - 35 mm<sup>2</sup>, Cu  
 1 x DC generator disconnect switch  
 rated current: DC 250 A  
 included cable entry:  
 24 x ASM 16, 25 x ASM 20, 2 x ASM 40

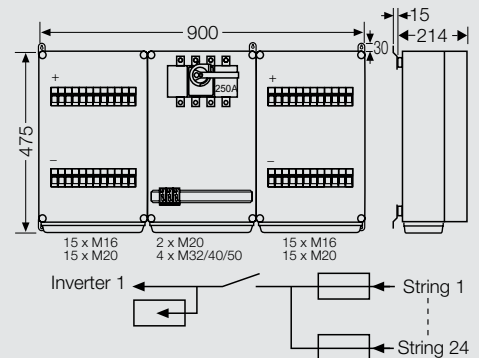

**Customised solutions?  
Contact us!**

See check list in the appendix!

## PV generator junction boxes with blocking diodes

- current per PV string **DC 1,5 A max.**
- rated current: DC 1000 V ( $U_{OC\ STC}$ )
- protection class: II
- suitable for outdoor installation, UV resistant
- ready for connection
- with stainless steel external brackets
- lid fasteners for tool operation
- material: thermoplastic
- colour: grey, RAL 7032
- degree of protection: IP 65



### Mi PV 4311 **12 x PV string on** **1 x inverter input** new

12 blocking diodes + and  
12 terminal blocks —  
connection: 1,5-6 mm<sup>2</sup>  
1 x DC generator disconnect switch  
rated current: DC 30 A  
\*utilization category: DC-21A  
included cable entry:  
12 x ASM 16, 14 x ASM 20

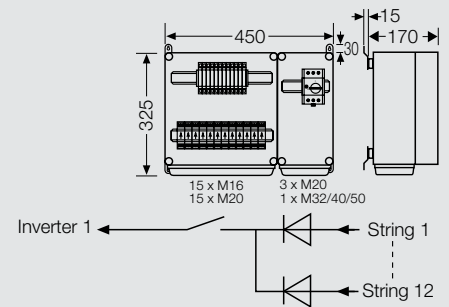

### Mi PV 4321 **12 x PV string on** **1 x inverter input** new

12 blocking diodes + and  
12 terminal blocks —  
connection: 1,5-6 mm<sup>2</sup>  
**1 x DC type 2 surge arrester**  
rated connecting capacity PE:  
1,5 - 16 mm<sup>2</sup>, Cu  
1 x DC generator disconnect switch  
rated current: DC 30 A  
\*utilization category: DC-21A  
included cable entry:  
12 x ASM 16, 15 x ASM 20

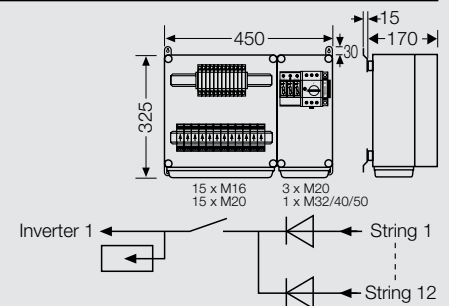

### Mi PV 4631 **24 x PV string on** **1 x inverter input** new

24 blocking diodes + and  
24 terminal blocks —  
connection: 1,5-6 mm<sup>2</sup>  
1 x DC generator disconnect switch  
rated current: DC 63 A  
\*utilization category: DC-21A  
included cable entry:  
24 x ASM 16, 24x ASM 20, 2 x ASM 25

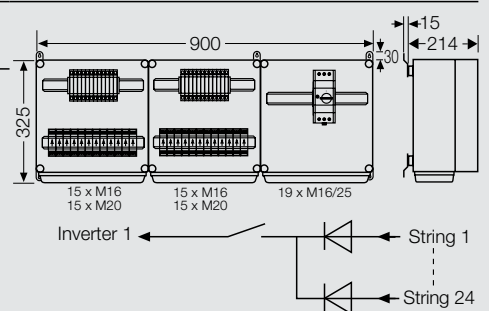

### Mi PV 4641 **24 x PV string on** **1 x inverter input** new

24 blocking diodes + and  
24 terminal blocks —  
connection: 1,5-6 mm<sup>2</sup>  
**1 x DC type 2 surge arrester**  
rated connecting capacity PE:  
1,5 - 16 mm<sup>2</sup>, Cu  
1 x DC generator disconnect switch  
rated current: DC 63 A  
\*utilization category: DC-21A  
included cable entry:  
24 x ASM 16, 24 x ASM 20, 3 x ASM 25

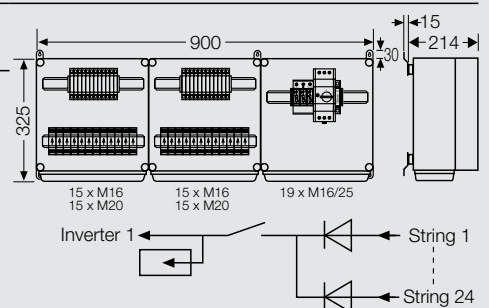

**Customised solutions? Contact us!**  
See check list in the appendix!

Delivery date of PV generator junction boxes with blocking diodes on request.

\* Utilization category for switch disconnectors:  
DC-21A = Switching ohmic loads inclusively moderate overload

## Photovoltaic

Standardised and individual solutions for generator junction boxes  
Ready for connection in accordance with IEC 60 364-7-712.



**Product:** Mi PV 1263

**Property:** Poco Furniture Store, Herne, Germany

**Area of application:** Outdoor installation

**Details:** Total power 300 kWp, 40 inverters

**Requirements:** High degree of protection IP 65: dust-proof and water-protected, high impact strength, temperature and UV resistance, corrosion resistance



**Product:** Customised solution

**Subject:** Kiefer-Glas-Solar

**Area of application:** Indoor installation

**Unique features:** DC collector with six strands at one inverter input  
Strand fuse, type 2 surge arrester and 63 A generator disconnect switch

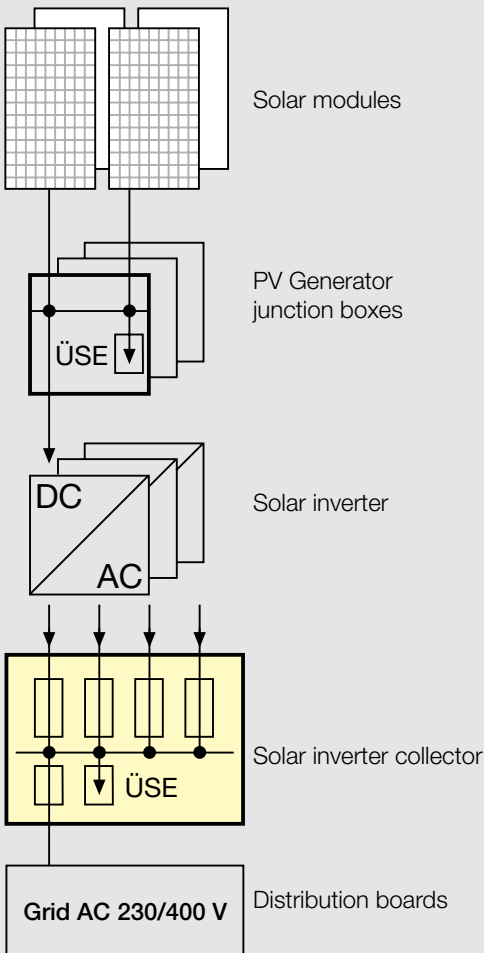

**Complete set:**  
pre-fabricated and tested solar inverter collector solutions



**Electrical data:**  
Rated voltage: AC 230/400 V  
1~ Inverters up to 11 kW  
3~ Inverters up to 33 kW  
optional with surge arrester



**Ambient conditions:**  
UV resistant  
Degree of protection: **IP 65**  
Protective measure: Total insulation   
Stainless steel external brackets  
optional: Combi climate glands to reduce condensation formation in outdoor installations.  
(order separately, see accessories).

**Protective device selection**

**Applying the simultaneity factor**

**Influenced by heat from the simultaneity factor and load**

**Photovoltaic installations need special ratings.**

Why are special solutions needed for PV plants?

The rating of photovoltaic installations differs significantly from normal building installations in that the installed devices are subject to a continuous load.

**Power distribution in buildings**

Protective device selection and rating to protect cables related to the current resp. the load of the consumer.

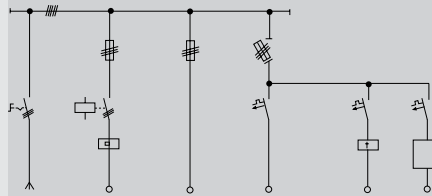

Select protective devices in the form of a fuse or miniature circuit breaker.

**Power distribution in photovoltaic plants**

Protective device selection and rating to protect cables related to the current resp. load of the solar inverter on the AC side.

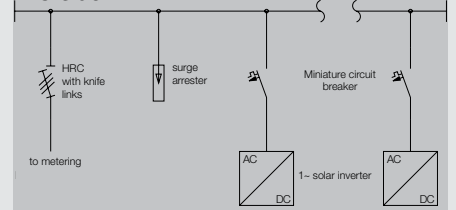

Select protective devices in the form of a fuse or miniature circuit breaker.

Due to the low simultaneity factor, the installed distribution board is often dimensioned according to the number of modules.

**PV plants have a simultaneity factor of 1!**

Which is why the distribution boards in PV plants have to be dimensioned differently and not simply according to the number of modules.

In consumption plants, power dissipation fluctuates depending on the number of consumers switched on at any one time.

**Low average effective power dissipation**

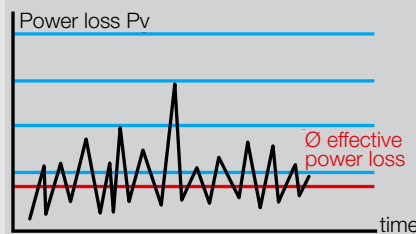

Constant high loads lead to **high average power dissipation** during the energy production phase.

Power dissipation therefore needs to be reduced to the point where the maximum temperature for devices is not exceeded.

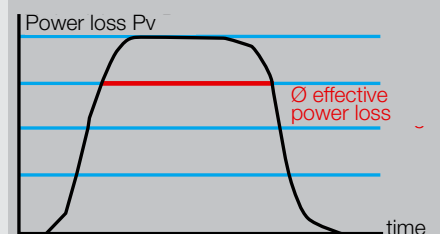

**Hensel solar inverter collectors correct dimensioned and tested: e.g. circuit-breaker box**

High power dissipation levels can lead to exceeding the maximum permitted temperature for devices meaning that protection devices can trip even when beneath rated current levels.

Photovoltaic installations require a special way of thinking about device dimensioning and selection!

The equipment of a circuit breaker box can be inferred from the following table.

**Table: Rating of solar inverter collector**

1~ solar inverter		Miniature circuit breaker		cable		glands	flange
maximum power output:	max. operating current	rated current	max. quantity	minimum cable cross section	minimum outside diameter		
2.8 kW	12 A	16 A	6 per row	3 x 2.5 mm <sup>2</sup>	11 mm	M 25	Mi FM 25
3.7 kW	16 A	20 A	5 per row	3 x 2.5 mm <sup>2</sup>	11 mm	M 25	Mi FM 25
4.8 kW	21 A	25 A	4 per row	3 x 4 mm <sup>2</sup>	13 mm	M 25	Mi FM 25
6.4 kW	28 A	32 A	3 per row	3 x 6 mm <sup>2</sup>	15 mm	M 25	Mi FM 25

3~ solar inverter		Miniature circuit breaker		cable		glands	flange
maximum power output:	max. operating current	rated current	max. quantity	minimum cable cross section	minimum outside diameter		
8.4 kW	12 A	16 A	6 per row	5 x 2.5 mm <sup>2</sup>	13.5 mm	M 25	Mi FM 32
11.1 kW	16 A	20 A	5 per row	5 x 2.5 mm <sup>2</sup>	13.5 mm	M 25	Mi FM 32
14.4 kW	21 A	25 A	4 per row	5 x 4 mm <sup>2</sup>	15.5 mm	M 32	Mi FM 32
19.3 kW	28 A	32 A	3/ per row	5 x 6 mm <sup>2</sup>	18 mm	M 32	Mi FM 32

Values are valid for max. ambient temperature of 35° C

Wiring of the busbar and connection at the switch disconnecter

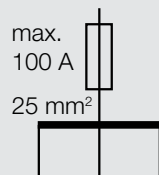

**1. Assessing simultaneity and load capacity**



**High simultaneity and load:**

- Devices spaced apart allow a better radiation of the power dissipation.
- Additional slots assure increased air circulation in the enclosure.
- The larger enclosure increase the dissipated power loss.

**2. Standard assembly aid**



- Installation devices are to be properly installed automatically with the help of positioning aids on the DIN rails.



- At the same time the miniature circuit breaker is in the proper position relative to the cover plate.

## Solar inverter collectors with circuit-breaker boxes



Leading inverter manufacturers recommend using MCBs as load disconnection devices.

- for inverters up to **6.4 kW**, 1~
- rated operating current **AC 28 A** per inverter
- rated voltage: AC 230/400 V
- suitable for outdoor installation, UV resistant
- with stainless steel external brackets
- in accordance with IEC 60 439-1
- busbar rated current: 250 A
- polarity of busbars: 5-pole
- material: thermoplastic
- colour: grey, RAL 7032
- protection class: II
- degree of protection: IP 65



### Mi PV 6111 Rated power 70 kW, connection of 1~ inverters

complete enclosure set, not assembled  
order cable entries separately

#### Feeding:

maximum 18x 1~ inverters  
**maximum quantity and ratings of MCBs according to table "Rating of solar inverter collectors"**

terminals for outgoing cables:

1.5-16 mm<sup>2</sup>, copper

18 terminals per PE+N

lid fastener for manual operation

#### Outgoing:

switch disconnector, 3-pole with knife links

1 terminal per PE+N

PE and N terminals for copper conductors

maximum back up fuse: 100 A

outgoing cable can be above or below

terminals for outgoing cables:

max. 35 mm<sup>2</sup>, copper

lid fasteners for tool operation

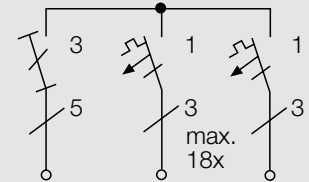
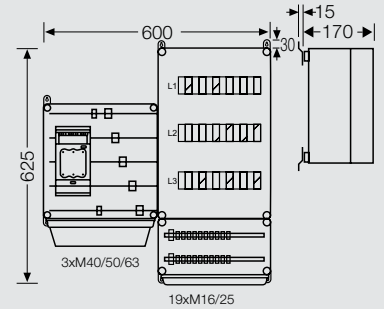

### Mi PV 6211 Rated power 70 kW, connection of 1~ inverters

complete enclosure set, not assembled  
order cable entries separately

#### Feeding:

maximum 18x 1~ inverters

**maximum quantity and ratings of MCBs according to table "Rating of solar inverter collectors"**

terminals for outgoing cables:

1.5-16 mm<sup>2</sup>, copper

18 terminals per PE+N

lid fastener for manual operation

#### Outgoing:

switch disconnector, 3-pole with knife links

1 terminal per PE+N

PE and N terminals for copper conductors

maximum back up fuse: 100 A

outgoing cable can be above or below

terminals for outgoing cables:

max. 35 mm<sup>2</sup>, copper

lid fasteners for tool operation

#### Overvoltage protection:

1 x AC type 2 surge arrester

with connection directly on the busbar in

the outgoing cable box

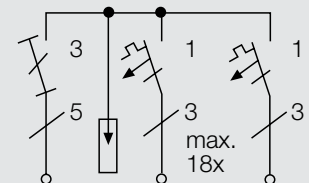
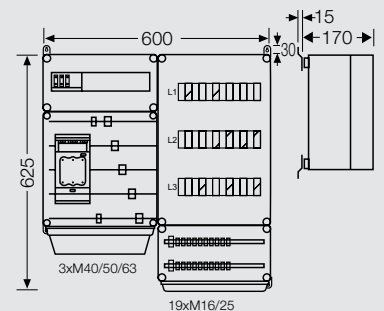

**Customised solutions?  
Contact us!**

See check list in the appendix!

Leading inverter manufacturers recommend using MCBs as load disconnection devices.

- for inverters up to **19.3 kW, 3~**
- rated operating current **AC 28 A** per inverter
- rated voltage: AC 230/400 V
- suitable for outdoor installation, UV resistant
- with stainless steel external brackets
- in accordance with IEC 60 439-1
- busbar rated current: 250 A
- polarity of busbars: 5-pole
- material: thermoplastic
- colour: grey, RAL 7032
- protection class: II
- degree of protection: IP 65



### Mi PV 6311 Rated power 70 kW, connection of 3~ inverters

complete enclosure set, not assembled  
order cable entries separately

**Feeding:**

max. 6x 3~ inverters

**maximum quantity and ratings of MCBs according to table "Rating of solar inverter collectors"**

terminals for outgoing cables:

1.5-16 mm<sup>2</sup>, copper  
12 terminals per PE+N

lid fastener for manual operation

**Outgoing:**

switch disconnector, 3 pole with knife links

1 terminal per PE+N

PE and N terminals for copper conductors

maximum back up fuse: 100 A

outgoing cable can be above or below

terminals for outgoing cables:

max. 35 mm<sup>2</sup>, copper

lid fasteners for tool operation

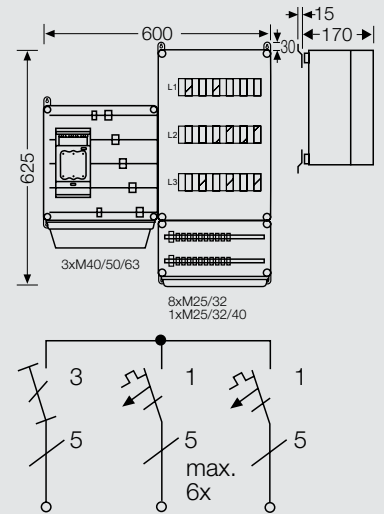

### Mi PV 6411 Rated power 70 kW, connection of 3~ inverters

complete enclosure set, not assembled  
order cable entries separately

**Feeding:**

max. 6x 3~ inverters

**maximum quantity and ratings of MCBs according to table "Rating of solar inverter collectors"**

terminals for outgoing cables:

1.5-16 mm<sup>2</sup>, copper  
12 terminals per PE+N

lid fastener for manual operation

**Outgoing:**

switch disconnector, 3 pole with knife link

1 terminal per PE+N

PE and N terminals for copper conductors

maximum back up fuse: 100 A

outgoing cable can be above or below

terminals for outgoing cables:

max. 35 mm<sup>2</sup>, copper

lid fasteners for tool operation

**Overvoltage protection:**

1 x AC type 2 surge arrester

with connection directly on the busbar in

the outgoing cable box

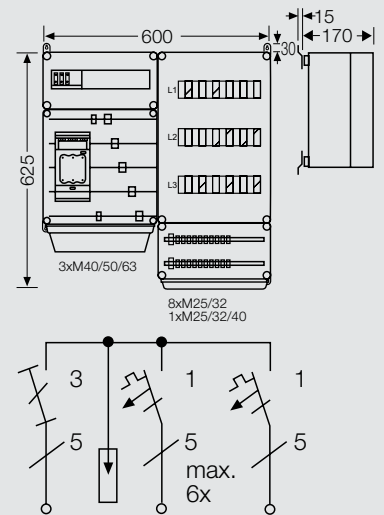

**Customised solutions?  
Contact us!**

See check list in the appendix!

Leading inverter manufacturers recommend using MCBs as load disconnection devices.

- for inverters up to **6.4 kW, 1~**
- rated operating current **AC 28 A** per inverter
- rated voltage: AC 230/400 V
- suitable for outdoor installation, UV resistant
- with stainless steel external brackets
- in accordance with IEC 60 439-1
- busbar rated current: 250 A
- polarity of busbars: 5-pole
- material: thermoplastic
- colour: grey, RAL 7032
- protection class: II
- degree of protection: IP 65



**Mi PV 6123 Rated power 140 kW, connection of 1~ inverters**

complete enclosure set, not assembled  
order cable entries separately

**Feeding:**

maximum 36x 1~ inverters  
**maximum quantity and ratings of MCBs according to table "Rating of solar inverter collectors"**

terminals for outgoing cables:

1.5-16 mm<sup>2</sup>, copper  
36 terminals per PE+N  
lid fastener for manual operation

**Outgoing:**

switch disconnector, 3 pole with knife links  
M 10 connection  
maximum back up fuse: 250 A  
outgoing cable can be above or below lid fasteners for tool operation

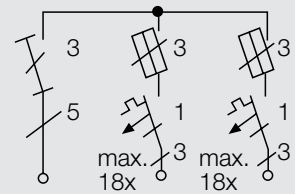
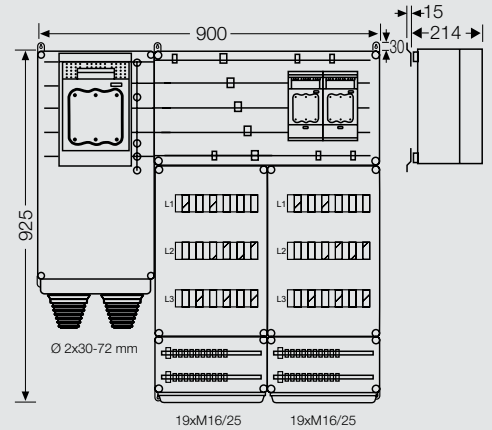

**Mi PV 6223 Rated power 140 kW, connection of 1~ inverters**

complete enclosure set, not assembled  
order cable entries separately

**Feeding:**

maximum 36x 1~ inverters  
**maximum quantity and ratings of MCBs according to table "Rating of solar inverter collectors"**

terminals for outgoing cables:

1.5-16 mm<sup>2</sup>, copper  
36 terminals per PE+N  
lid fastener for manual operation

**Outgoing:**

switch disconnector, 3 pole with knife links  
M 10 connection  
maximum back up fuse: 250 A  
outgoing cable can be above or below lid fasteners for tool operation

**Overvoltage protection:**

1 x AC type 2 surge arrester  
with connection via HRC 00 fuse switch disconnector

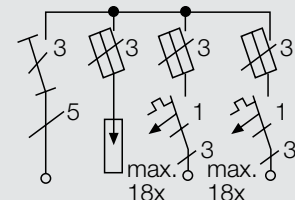
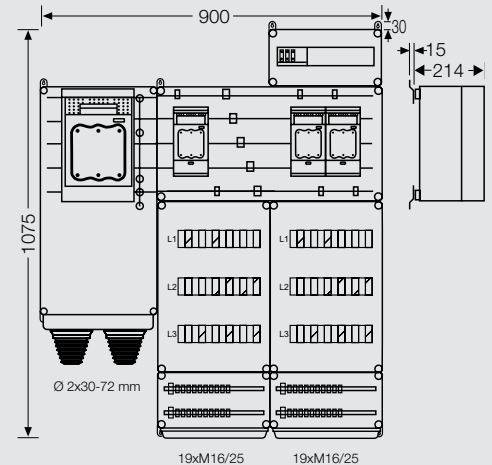

**Customised solutions? Contact us!**

See check list in the appendix!

Leading inverter manufacturers recommend using MCBs as load disconnection devices.

- for inverters up to **19.3 kW, 3~**
- rated operating current **AC 28 A** per inverter
- rated voltage: AC 230/400 V
- suitable for outdoor installation, UV resistant
- with stainless steel external brackets
- in accordance with IEC 60 439-1
- busbar rated current: 250 A
- polarity of busbars: 5-pole
- material: thermoplastic
- colour: grey, RAL 7032
- protection class: II
- degree of protection: IP 65



### Mi PV 6323 Rated power 140 kW, connection of 3~ inverters

complete enclosure set, not assembled  
order cable entries separately

**Feeding:**

maximum 12x 3~ inverters  
**maximum quantity and ratings of MCBs according to table "Rating of solar inverter collectors"**

terminals for outgoing cables:

1.5-16 mm<sup>2</sup>, copper  
24 terminals per PE+N  
Lid fastener for manual operation

**Outgoing:**

switch disconnector, 3 pole with knife links  
M 10 connection  
maximum back-up fuse: 250 A  
outgoing cable can be above or below lid fasteners for tool operation

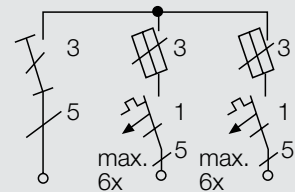
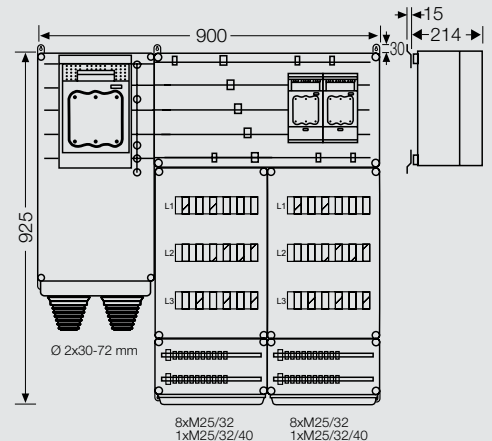

### Mi PV 6423 Rated power 140 kW, connection of 3~ inverters

complete enclosure set, not assembled  
order cable entries separately

**Feeding:**

maximum 12x 3~ inverters  
**maximum quantity and ratings of MCBs according to table "Rating of solar inverter collectors"**

terminals for outgoing cables:

1.5-16 mm<sup>2</sup>, copper  
24 terminals per PE+N  
lid fastener for manual operation

**Outgoing:**

switch disconnector, 3 pole with knife links  
M 10 connection  
maximum back-up fuse: 250 A  
outgoing cable can be above or below lid fasteners for tool operation

**Overvoltage protection:**

1 x AC type 2 surge arrester with connection via HRC 00 fuse switch disconnector

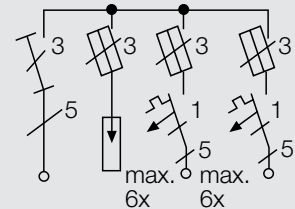
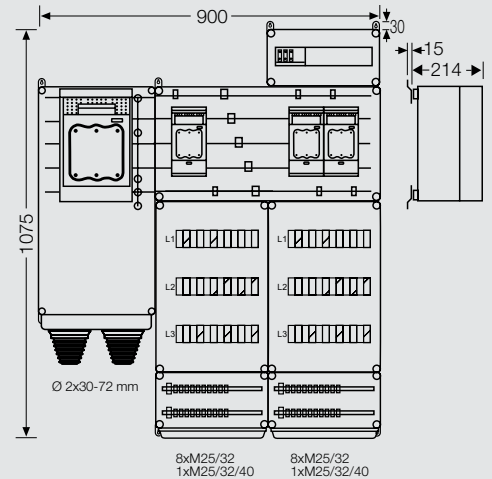

**Customised solutions? Contact us!**  
See check list in the appendix!

- for inverters up to **7 kW, 1~**
- rated operating current **AC 30 A** per inverter
- rated voltage: AC 230/400 V
- suitable for outdoor installation,  
UV resistant
- with stainless steel external brackets
- in accordance with IEC 60 439-1
- busbar rated current: 250 A
- polarity of busbars: 5-pole
- material: thermoplastic
- colour: grey, RAL 7032
- protection class: II
- degree of protection: IP 65

**Mi PV 5112 Rated power 70 kW,  
connection of 1~ inverters**

complete enclosure set, not assembled  
order cable entries separately

**Feeding:**

5 x 63 A, 3-pole D 02, E 18,  
gauge sleeve system  
for 63 A fuse links  
terminals for incoming cables:  
4-35 mm<sup>2</sup>, copper  
terminals for outgoing cables:  
1.5-16 mm<sup>2</sup>, copper  
15 terminals per PE+N  
lid fastener for manual operation

**Outgoing:**

switch disconnecter, 3 pole with knife links  
1 terminal per PE+N  
PE and N terminals for copper conductors  
maximum back-up fuse: 125 A  
outgoing cable can be above or below  
terminals for outgoing cables:  
max. 35 mm<sup>2</sup>, copper  
lid fasteners for tool operation

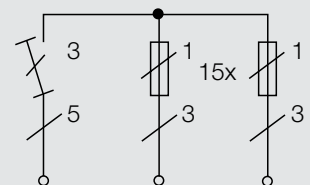
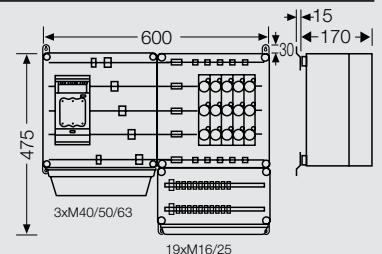
**Mi PV 5212 Rated power 70 kW,  
connection of 1~ inverters**

complete enclosure set, not assembled  
order cable entries separately

**Feeding:**

5 x 63 A, 3-pole D 02, E 18,  
gauge sleeve system  
for 63 A fuse links  
terminals for incoming cables:  
4-35 mm<sup>2</sup>, copper  
terminals for outgoing cables:  
1.5-16 mm<sup>2</sup>, copper  
15 terminals per PE+N  
lid fastener for manual operation

**Outgoing:**

switch disconnecter, 3 pole with knife links  
1 terminal per PE+N  
PE and N terminals for copper conductors  
maximum back-up fuse: 125 A  
outgoing cable can be above or below  
terminals for outgoing cables:  
max. 35 mm<sup>2</sup>, copper  
lid fasteners for tool operation

**Overvoltage protection:**

1 x AC type 2 surge arrester  
with connection directly on the busbar in  
the outgoing cable box

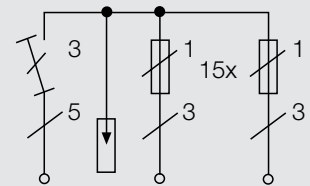
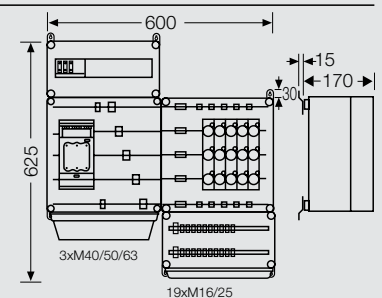

**Customised  
solutions?  
Contact us!**

See check list in the appendix!

- for inverters up to **21 kW, 3~**
- rated operating current **AC 30 A** per inverter
- rated voltage: AC 230/400 V
- suitable for outdoor installation,  
UV resistant
- with stainless steel external brackets
- in accordance with IEC 60 439-1
- busbar rated current: 250 A
- polarity of busbars: 5-pole
- material: thermoplastic
- colour: grey, RAL 7032
- protection class: II
- degree of protection: IP 65

**Mi PV 5312 Rated power 70 kW,  
connection of 3~ inverters**

complete enclosure set, not assembled  
order cable entries separately

**Feeding:**

5 x 63 A, 3-pole D 02, E 18,  
gauge sleeve system  
for 63 A fuse links

terminals for incoming cables:

4-35 mm<sup>2</sup>, copper

terminals for outgoing cables:

1.5-16 mm<sup>2</sup>, copper

5 terminals per PE+N

lid fastener for manual operation

**Outgoing:**

switch disconnecter, 3 pole with knife links

1 terminal per PE+N

PE and N terminals for copper conductors

maximum back-up fuse: 125 A

outgoing cable can be above or below

terminals for outgoing cables:

max. 35 mm<sup>2</sup>, copper

lid fasteners for tool operation

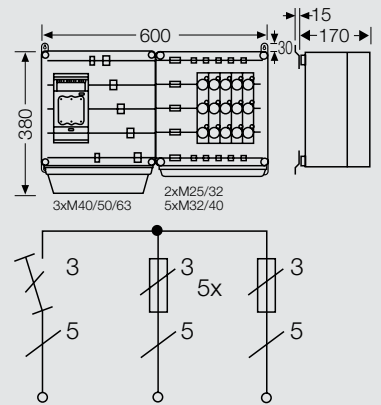
**Mi PV 5412 Rated power 70 kW,  
connection of 3~ inverters**

complete enclosure set, not assembled  
order cable entries separately

**Feeding:**

5 x 63 A, 3-pole D 02, E 18,  
gauge sleeve system  
for 63 A fuse links

terminals for incoming cables:

4-35 mm<sup>2</sup>, copper

terminals for outgoing cables:

1.5-16 mm<sup>2</sup>, copper

5 terminals per PE+N

lid fastener for manual operation

**Outgoing:**

switch disconnecter, 3 pole with knife links

1 terminal per PE+N

PE and N terminals for copper conductors

maximum back-up fuse: 125 A

outgoing cable can be above or below

terminals for outgoing cables:

max. 35 mm<sup>2</sup>, copper

lid fasteners for tool operation

**Overvoltage protection:**

1 x AC type 2 surge arrester

with connection directly on the busbar in

the outgoing cable box

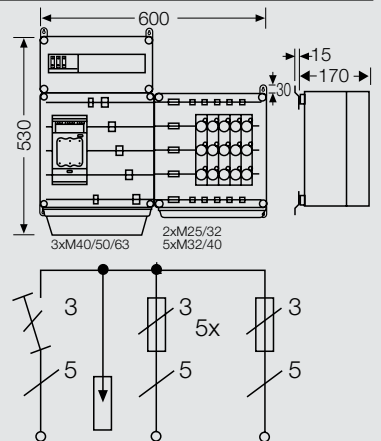

**Customised  
solutions?  
Contact us!**

See check list in the appendix!

## Solar inverter collectors with neozed fuse bases 63 A



- for inverters up to **7 kW, 1~**
- rated operating current **AC 30 A** per inverter
- rated voltage: AC 230/400 V
- suitable for outdoor installation,  
UV resistant
- with stainless steel external brackets
- in accordance with IEC 60 439-1
- busbar rated current: 250 A
- polarity of busbars: 5-pole
- material: thermoplastic
- colour: grey, RAL 7032
- protection class: II
- degree of protection: IP 54



Sample installation

### Mi PV 5124 Rated power 140 kW, connection of 1~ inverters

complete enclosure set, not assembled  
order cable entries separately

**Feeding:**

12 x 63 A, 3-pole D 02, E 18,  
gauge sleeve system  
for 63 A fuse links

terminals for incoming cables:

4-35 mm<sup>2</sup>, copper

terminals for outgoing cables:

1.5-16 mm<sup>2</sup>, copper

36 terminals per PE+N

lid fastener for manual operation

**Outgoing:**

switch disconnecter, 3 pole with knife links

M 10 connection

maximum back-up fuse: 250 A

outgoing cable can be above or below

lid fasteners for tool operation

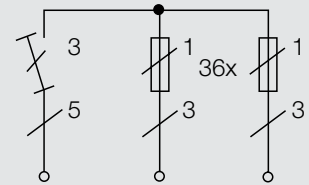
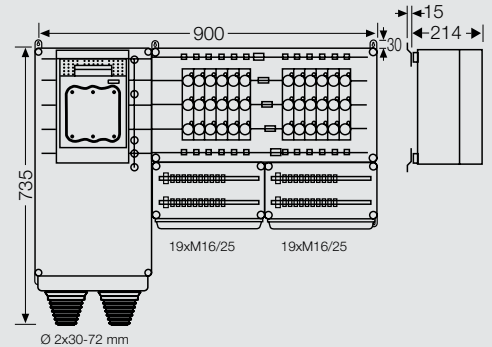

Sample installation

### Mi PV 5224 Rated power 140 kW, connection of 1~ inverters

complete enclosure set, not assembled  
order cable entries separately

**Feeding:**

12 x 63 A, 3-pole D 02, E 18,  
gauge sleeve system  
for 63 A fuse links

terminals for incoming cables:

4-35 mm<sup>2</sup>, copper

terminals for outgoing cables:

1.5-16 mm<sup>2</sup>, copper

36 terminals per PE+N

lid fastener for manual operation

**Outgoing:**

switch disconnecter, 3 pole with knife links

M 10 connection

maximum back-up fuse: 250 A

outgoing cable can be above or below

lid fasteners for tool operation

**Overvoltage protection:**

1 x AC type 2 surge arrester

with connection via neozed fuse base

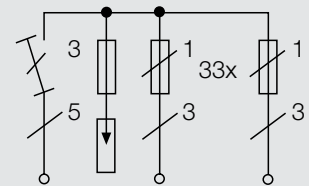
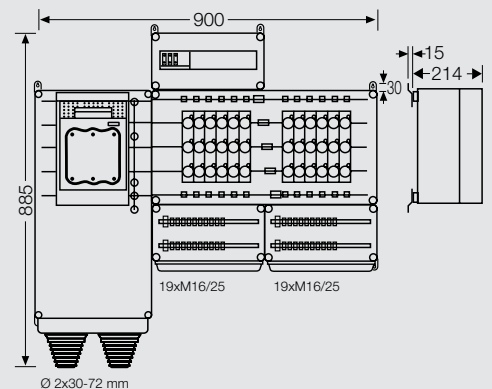

**Customised solutions?  
Contact us!**

See check list in the appendix!

## Solar inverter collectors with neozed fuse bases 63 A

- for inverters up to **21 kW, 1~**
- rated operating current **AC 30 A** per inverter
- rated voltage: AC 230/400 V
- suitable for outdoor installation,  
UV resistant
- with stainless steel external brackets
- in accordance with IEC 60 439-1
- busbar rated current: 250 A
- polarity of busbars: 5-pole
- material: thermoplastic
- colour: grey, RAL 7032
- protection class: II
- degree of protection: IP 54



Sample installation

### Mi PV 5324 Rated power 140 kW, connection of 3~ inverters

complete enclosure set, not assembled  
order cable entries separately

**Feeding:**

12 x 63 A, 3-pole D 02, E 18,  
gauge sleeve system  
for 63 A fuse links  
terminals for incoming cables:  
4-35 mm<sup>2</sup>, copper  
terminals for outgoing cables:  
1.5-16 mm<sup>2</sup>, copper  
12 terminals per PE+N

lid fastener for manual operation

**Outgoing:**

switch disconnecter, 3 pole with knife links  
M 10 connection  
maximum back-up fuse: 250 A  
outgoing cable can be above or below  
lid fasteners for tool operation

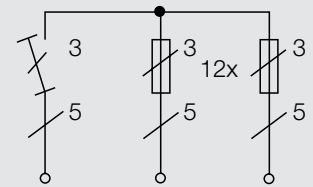
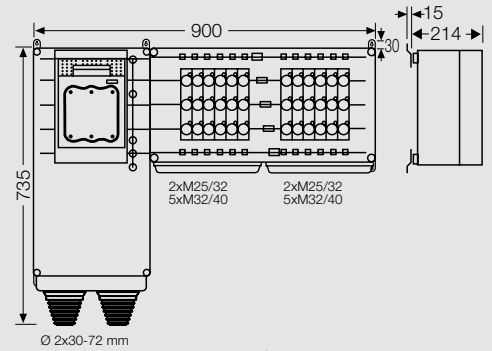

Sample installation

### Mi PV 5424 Rated power 140 kW, connection of 3~ inverters

complete enclosure set, not assembled  
order cable entries separately

**Feeding:**

11 x 63 A, 3-pole D 02, E 18,  
gauge sleeve system  
for 63 A fuse links  
terminals for incoming cables:  
4-35 mm<sup>2</sup>, copper  
terminals for outgoing cables:  
1.5-16 mm<sup>2</sup>, copper  
12 terminals per PE+N

lid fastener for manual operation

**Outgoing:**

switch disconnecter, 3 pole with knife links  
M 10 connection  
maximum back-up fuse: 250 A  
outgoing cable can be above or below  
lid fasteners for tool operation

**Overvoltage protection:**

1 x AC type 2 surge arrester  
with connection via neozed fuse base

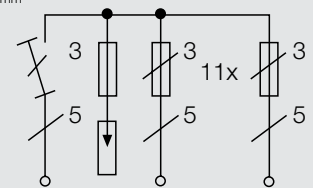
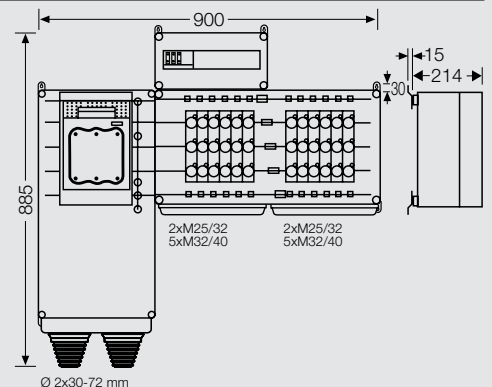

**Customised solutions?  
Contact us!**

See check list in the appendix!

## Solar inverter collectors with switch disconnectors for D 02 fuses 63 A



Leading inverter manufacturers recommend using switch disconnectors as disconnection devices.

- for inverters up to **11 kW, 1~**
- rated operating current **AC 48 A** per inverter
- rated voltage: AC 230/400 V
- suitable for outdoor installation, UV resistant
- with stainless steel external brackets
- in accordance with IEC 60 439-1
- busbar rated current: 250 A
- polarity of busbars: 5-pole
- material: thermoplastic
- colour: grey, RAL 7032
- protection class: II
- degree of protection: IP 54



### Mi PV 5123 Rated power 140 kW, connection of 1~ inverters

complete enclosure set, not assembled  
order cable entries separately

**Feeding:**

6 x 63 A, 3-pole D 02, E 18,  
1 or 3-pole switching  
for 63 A fuse links

terminals for outgoing cables:

1.5-16 mm<sup>2</sup>, copper  
18 terminals per PE+N

lid fastener for manual operation

**Outgoing:**

switch disconnector, 3 pole with knife link  
M 10 connection

maximum back-up fuse: 250 A

outgoing cable can be above or below  
lid fasteners for tool operation

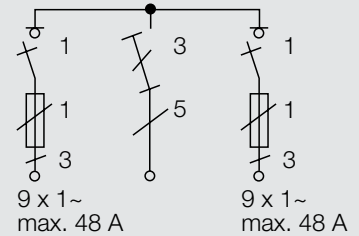
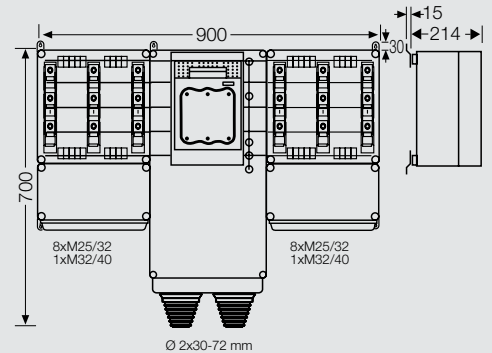

### Mi PV 5223 Rate power 140 kW, connection of 1~ inverters

complete enclosure set, not assembled  
order cable entry separately

**Feeding:**

6 x 63 A, 3-pole D 02, E 18,  
1 or 3-pole switching  
for 63 A fuse links

terminals for outgoing cables:

1.5-16 mm<sup>2</sup>, Cu  
18 terminals per PE+N

lid fastener for manual operation

**Outgoing:**

switch disconnector, 3 pole with knife links  
M 10 connection

maximum back-up fuse: 250 A

outgoing cable can be above or below  
lid fasteners for tool operation

**Overvoltage protection:**

1 x AC type 2 surge arrester  
with connection via neozed fuse element

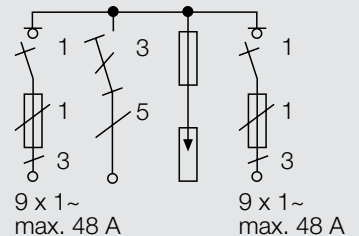
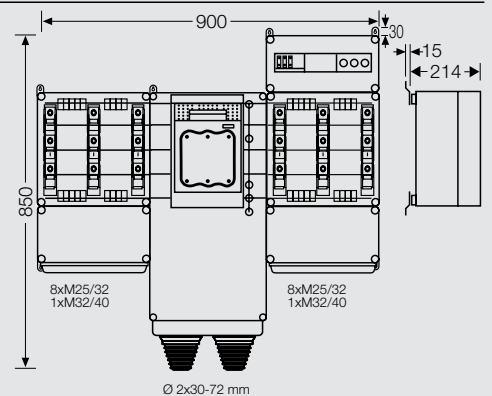

**Customised solutions?  
Contact us!**

See check list in the appendix!

## Solar inverter collectors with switch disconnectors for D 02 fuses 63 A



Leading inverter manufacturers recommend using switch disconnectors as disconnection devices.

- for inverters up to **33 kW, 3~**
- rated operating current **AC 48 A** per inverter
- rated voltage: AC 230/400 V
- suitable for outdoor installation, UV resistant
- with stainless steel external brackets
- in accordance with IEC 60 439-1
- busbar rated current: 250 A
- polarity of busbars: 5-pole
- material: thermoplastic
- colour: grey, RAL 7032
- protection class: II
- degree of protection: IP 54



### Mi PV 5323 Rated power 140 kW, connection of 3~ inverters

complete enclosure set, not assembled  
order cable entry separately

**Feeding:**

6 x 63 A, 3-pole D 02, E 18,  
1 or 3-pole switching  
for 63 A fuse links  
terminals for outgoing cables:  
1.5-16 mm<sup>2</sup>, Cu  
6 terminals per PE+N  
lid fastener for manual operation

**Outgoing:**

switch disconnector, 3 pole with knife links  
M 10 connection  
maximum back-up fuse: 250 A  
outgoing cable can be above or below  
lid fasteners for tool operation

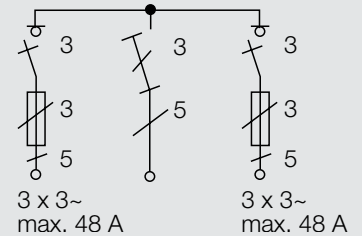
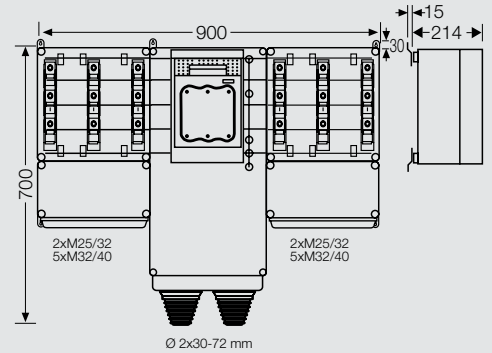

### Mi PV 5423 Rated power 140 kW, connection of 3~ inverters

complete enclosure set, not assembled  
order cable entry separately

**Feeding:**

6 x 63 A, 3-pole D 02, E 18,  
1 or 3-pole switching  
for 63 A fuse links  
terminals for outgoing cables:  
1.5-16 mm<sup>2</sup>, Cu  
6 terminals per PE+N  
lid fastener for manual operation

**Outgoing:**

switch disconnector, 3 pole with knife links  
M 10 connection  
maximum back-up fuse: 250 A  
outgoing cable can be above or below  
lid fasteners for tool operation

**Overvoltage protection:**

1 x AC type 2 surge arrester  
with connection via neozed fuse element

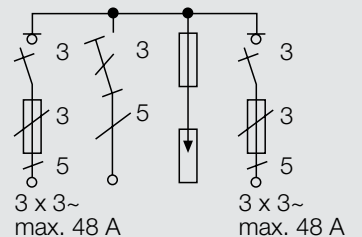
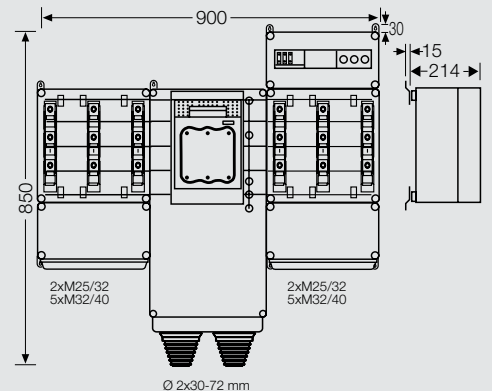

Customised solutions?  
Contact us!  
See check list in the appendix!

- suitable for outdoor installation, UV resistant

- material: thermoplastic
- colour: grey, RAL 7032
- protection class: II
- degree of protection: IP 65

**Mi PV 5511 PV terminal box**

extension set, ready for connection  
number of terminals per PE+N  
12 x 1.5-16 mm<sup>2</sup>, Cu  
1 x 4-35 mm<sup>2</sup>, Cu  
with wall gasket,  
with 100 A wiring between PE+N terminals  
and busbars  
separately order flange for cable entry

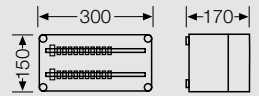
**Mi PV 5611 Surge protection device box (SPD)**

extension set, ready for connection  
with wall gasket  
with pre-assembled connection cables  
with blanking strip for unused DIN rail  
openings  
1 modular AC type 2 surge arrester  
for 3-phase TN  
rated voltage: AC 230/400 V  
protection level  $\leq 1.0$  kV  
defect display through red marking

**Connection:**

for 70 kW solar inverter collector  
outgoing cable box directly on the busbar  
order busbar terminals for direct connection separately  
at 140 kW solar inverter collectors via  
neozed fuse element or HRC 00 fuse  
switch disconnector

**Mi PV 1318 Circuit-breaker box  
18 modules, 3 x 6 x 18 mm**

3-row  
for installation of DIN rail equipment in  
accordance with DIN 43 880  
**maximum quantity and ratings of  
MCBs and flange selection according  
to table "Rating of PV solar inverter  
collectors"**  
without PE and N terminal  
with blanking strips for unused DIN rail  
openings  
lid fastener for manual operation

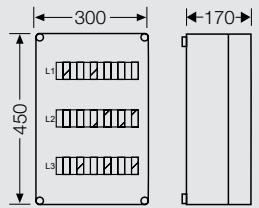
**Box walls with metric cable entries:**



Wall 1	Wall 2	Wall 3	Wall 4
1 x M 20	2 x M 20	4 x M 25	1 x M 20
1 x M 32/40	10 x M 25	3 x M 40/50	4 x M 25
	1 x M 32/40		1 x M 32/40
			3 x M 40/50

**Customised solutions?  
Contact us!**

See check list in the appendix!

- suitable for outdoor installation, UV resistant

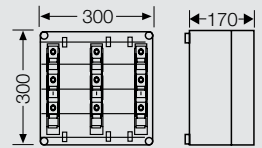
- material: thermoplastic
- colour: grey, RAL 7032
- protection class: II
- degree of protection: IP 65

**Mi PV 3266 Fuse box with switch disconnector for D 02 fuses, 63 A**

3 x 63 A, 3-pole, D 02, E 18,  
1- or 3-pole switching  
terminals for outgoing cables:  
1.5 -16 mm<sup>2</sup>, copper  
3 terminals per PE+N  
rated voltage: AC 400 V  
busbar rated current: 250 A  
polarity of busbars: 5-pole  
lid fastener for manual operation  
order busbar connector Mi SV 25 separately for combination

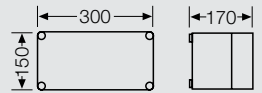
**Mi 0101 Empty box, box size 1**

maximum installation depth  
with built-in mounting plate 146 mm  
with built-in DIN rail 135 mm

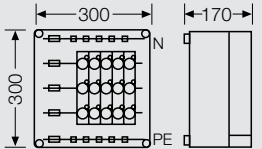
**Mi3235 Fuse box with neozed fuse bases 63 A**

5 x 63 A, 3-pole  
D0 2, E 18, gauge sleeve system  
terminals for incoming cables:  
4-35 mm<sup>2</sup>, copper  
terminals for outgoing cables:  
1.5-16 mm<sup>2</sup>, copper  
5 terminals per PE+N  
rated voltage: AC 400 V  
busbars rated current: 250 A  
polarity of busbars: 5-pole  
lid fastener for manual operation  
order busbar connector Mi SV 25 separately for combination

**See Hensel  
main catalog for further  
extension boxes!**

**Box walls with metric cable entries:**

**Wall 1**

1 x M 20  
1 x M 32/40

**Wall 2**

2 x M 20  
10 x M 25  
1 x M 32/40

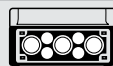

**Wall 3**

4 x M 25  
3 x M 40/50

**Customised solutions?  
Contact us!**

See check list in the appendix!

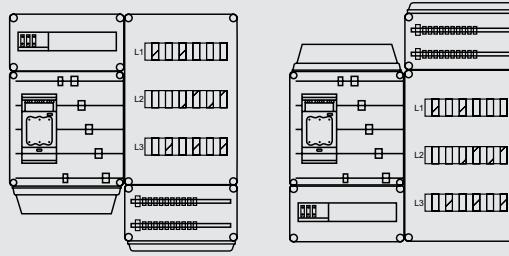
**Installation variations of a complete set**



**Wiring from the same direction**

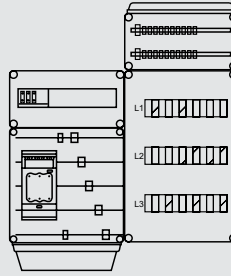

**Wiring from different directions**

**Extension of a complete set**

**Mi PV 6211 (70 kW) complete set**

Extension:

Mi PV 1318 circuit breaker box, Mi PV 5511 PV terminal box,  
Mi WD 2 wall gasket and Mi FM 32 flange

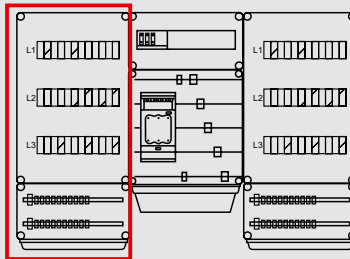

**Extension Complete set part**

**Extension of terminal compartment for the 70 mm<sup>2</sup> connection**

**Mi PV 6211 (70 kW) complete set**

Extension:

Mi 010X empty box, Mi WD 2 wall gasket and terminal for direct busbar connection KS 70 F

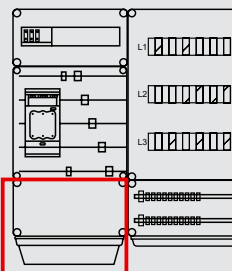

**Extension part**

Assembly of a complete set

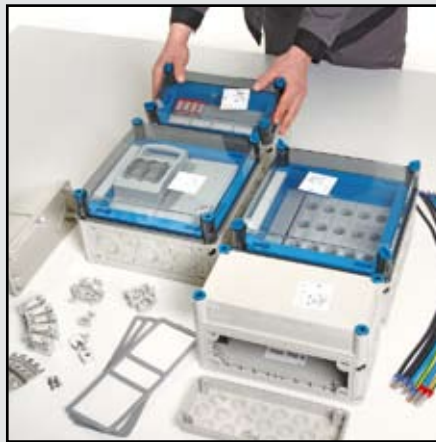

## Photovoltaic

Every photovoltaic object has its own topology. The challenges can often be met with pre-fabricated solutions. Individually engineered solar inverter collectors are also not a problem, even as part of metering in adherence to regulations of power supply companies.



**Product:** Customised solution **ENYSUN**  
**Subject:** Hannes management company, Herten, Germany  
**Area of application:** Indoor installation  
**Details:** Total power 450 kWp, 8 inverters  
**Unique features:** 8 central inverters via RCD and screw-type fuse bases



**Product:** Customised solution **ENYSUN**  
**Subject:** Solarpark Edertal II  
**Area of application:** Outdoor installation  
**Details:** Total power 1200 kWp, 151 inverters, delivery directly into mid-voltage grids  
**Unique features:** Inverter collector with mains disconnect switch in polyester outdoor cabinet



**Product:** Mi PV 5324 **ENYSUN**  
**Subject:** Frankfurt Trade Fair, Frankfurt/Main, Germany  
**Area of application:** Outdoor installation  
**Details:** Total power 490 kWp, 45 inverters



**Empty boxes  
Box walls without knockouts**

- suitable for outdoor installation, UV resistant

- material: thermoplastic
- colour: black, RAL 9011
- protection class II
- degree of protection: **IP 66**

**KF PV 0100**

wall surface can be drilled individually for cable entry max. M 20  
 mounting width: 59 mm  
 mounting height: 66 mm  
 max. installation depth: 37 mm

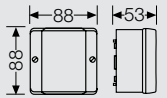
**KF PV 0200**

wall surface can be drilled individually for cable entry max. M 20  
 mounting width: 69 mm  
 mounting height: 76 mm  
 max. installation depth: 42 mm

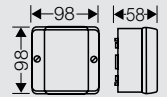
**KF PV 0300**

wall surface can be drilled individually for cable entry max. M 32  
 mounting width: 114 mm  
 mounting height: 94 mm  
 max. installation depth: 52 mm

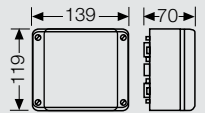
**KF PV 0400**

wall surface can be drilled individually for cable entry max. M 32  
 mounting width: 141 mm  
 mounting height: 99 mm  
 max. installation depth: 64 mm

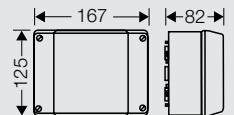
**KF PV 0500**

wall surface can be drilled individually for cable entry max. M 40  
 mounting width: 173 mm  
 mounting height: 133 mm  
 max. installation depth: 97 mm

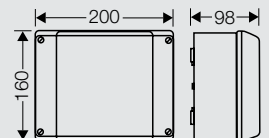
**KF PV 0600**

wall surface can be drilled individually for cable entry max. M 50  
 mounting width: 230 mm  
 mounting height: 180 mm  
 max. installation depth: 95 mm

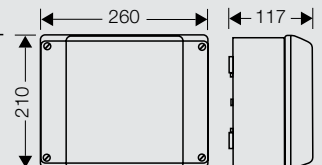

**KF PV 0700**

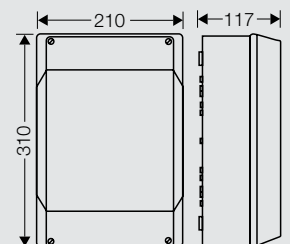
wall surface can be drilled individually for cable entry max. M 50  
 mounting width: 280 mm  
 mounting height: 180 mm  
 max. installation depth: 88 mm



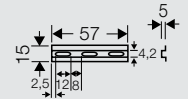

**TSD 02 DIN rail**

max. installation depth 32 mm  
for cable junction boxes D x020, D x120, KF x020, KD x020  
and empty box KF PV 0100, top hat profile 15 mm  
with fixing screws

**TSD 04 DIN rail**

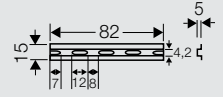
max. installation depth 40 mm  
for cable junction boxes D x040, KF x040, KD x040  
and empty box KF PV 0200, top hat profile 15 mm  
with fixing screws

**TSK 06 DIN rail**

max. installation depth 44.5 mm  
for cable junction boxes K x060, KF x060, KD x060  
and empty box KF PV 0300, top hat profile 15 mm  
with fixing screws

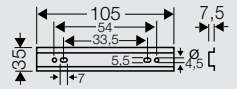
**TSK 10 DIN rail**

max. installation depth 56.5 mm  
for cable junction boxes K x100, KF x100, KD x100  
and empty box KF PV 0400, top hat profile 15 mm  
with fixing screws

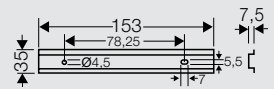
**TSK 25 DIN rail**

max. installation depth 71.5 mm  
for cable junction boxes K x250, KF x250, K x350, KF x350,  
KD x250, KD x350 and empty boxes KF PV 0500, KF PV 0600  
top hat profile 15 mm  
with fixing screws

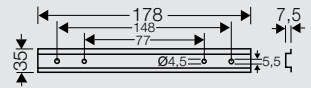
**TSK 35 DIN rail**

max. installation depth 80.5 mm  
for cable junction boxes K x350, KF x350, KD x350  
and empty box KF PV 0600, top hat profile 15 mm  
with fixing screws

**TSK 50 DIN rail**

max. installation depth 80.5 mm  
for cable junction boxes K x500, KF x500  
and empty box KF PV 0700, top hat profile 15 mm  
with fixing screws

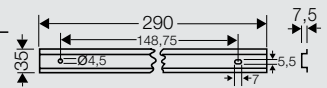
**DK AL 2 External brackets**

for external wall fixing of cable junction boxes type D, K, KF, KX, KD  
and empty box KF PV,  
external brackets: 2 items  
material: V2A stainless steel

## KV small-type distribution boards

### Box walls without knockouts

- suitable for outdoor installation, UV resistant
  - for the installation of DIN rail equipment, top hat profile 35 mm
  - with cable entry cover
  - with transparent door
  - protective cover can be cut out
- material: thermoplastic
  - colour: grey, RAL 7035

**KV PC 8104 IP 65**
**4.5 modules, 1 x 4.5 x 18 mm**

1-row  
 protection class: II   
 insulated box for photovoltaic plants of  
 up to AC 690 V / DC 1000 V

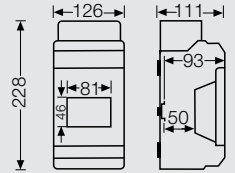
**KV PC 8109 IP 65**
**9 modules, 1 x 9 x 18 mm**

1-row  
 protection class: II &   
 insulated box for photovoltaic plants of  
 up to AC 690 V / DC 1000 V

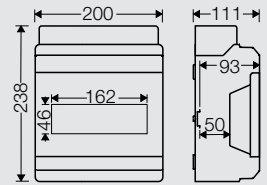
**KV ES 3 Locking device**
**for small-type distribution boards 3 - 9 modules**

for KV 9325, KV 9363  
 with profile cylinder lock  
 with 2 keys

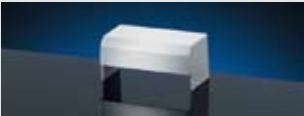
**KV EB 04 Cable entry cover**
**for small-type distribution boards with 4.5 modules**

for replacement purposes (1 cable entry cover included with supply of the board)

**KV EB 09 Cable entry cover**
**for small-type distribution boards with 9 modules**

for KV 9325, KV 9363  
 for replacement purposes (1 cable entry cover included with supply of the board)

**KV BP 04 Mounting plate**

for wall and post installation  
 for outdoor box installation with KV XX04 and KV PC XX04  
 assembly kit containing 1 stainless steel plate, screws and fixing brackets  
 post diameter at least 40 mm

**KV BP 09 Mounting plate**

for wall and post installation  
 for outdoor box installation with KV XX09 and KV PC XX09  
 assembly kit containing 1 stainless steel plate, screws and fixing brackets  
 post diameter at least 40 mm

**Terminals for  
direct busbar connection**

For solid (sol), stranded (s), flexible (f) copper conductors with gas-tight crimped end sleeve and for laminated wiring strip

**Hint:**  
For observance of insulation resistance clearances of 10 mm are necessary between different potentials and of 15 mm between conductive metal parts.

Mi fuse boxes diazed/neozed

Mi HRC fuse boxes, fuse bases and fuse switch disconnecter

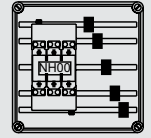
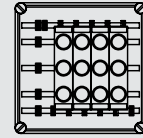

Type	for busbars	width	conductor cross section	wiring strip	tightening torque	busbar rated current 250 A	busbar rated current 250 A
<b>KS 16 F</b>	... x 5 mm	11 mm	1,5-16 mm <sup>2</sup> Cu		4 Nm	N PE	N PE



<b>KS 16 Z</b>	... x 10 mm	11 mm	1,5-16 mm <sup>2</sup> Cu		4 Nm	L1 L2 L3	L1 L2 L3
----------------	-------------	-------	---------------------------	--	------	----------------	----------------



<b>KS 35 F</b>	... x 5 mm	16 mm	4-35 mm <sup>2</sup> Cu	100 A: Mi VS 100 160 A: Mi VS 160	6 Nm	N PE	N PE
----------------	------------	-------	-------------------------	--------------------------------------	------	---------	---------



<b>KS 35 Z</b>	... x 10 mm	16 mm	4-35 mm <sup>2</sup> Cu	100 A: Mi VS 100 160 A: Mi VS 160	6 Nm	L1 L2 L3	L1 L2 L3
----------------	-------------	-------	-------------------------	--------------------------------------	------	----------------	----------------



<b>KS 70 F</b>	... x 5 mm	21 mm	10-70 mm <sup>2</sup> Cu	100 A: Mi VS 100 160 A: Mi VS 160	10 Nm	N PE	N PE
----------------	------------	-------	--------------------------	--------------------------------------	-------	---------	---------



<b>KS 70 Z</b>	... x 10 mm	21 mm	10-70 mm <sup>2</sup> Cu	100 A: Mi VS 100 160 A: Mi VS 160	10 Nm	L1 L2 L3	L1 L2 L3
----------------	-------------	-------	--------------------------	--------------------------------------	-------	----------------	----------------



<b>KS 120 F</b>	... x 5 mm	25 mm	25-120 mm <sup>2</sup> Cu	250 A: Mi VS 250	20 Nm		N PE
-----------------	------------	-------	---------------------------	------------------	-------	--	---------



<b>KS 120 Z</b>	... x 10 mm	25 mm	25-120 mm <sup>2</sup> Cu	250 A: Mi VS 250	20 Nm		L1 L2 L3
-----------------	-------------	-------	---------------------------	------------------	-------	--	----------------



<b>DA 240</b>	<b>Terminal for direct connection</b>						
---------------	---------------------------------------	--	--	--	--	--	--

up to 400 A  
for mounting onto switchgear with flat contact M10  
with insulating cover  
rated connecting capacity:  
35-70 mm<sup>2</sup> s (round), Cu/Alu  
50-185 mm<sup>2</sup> s (sector), Cu/Alu  
35-50 mm<sup>2</sup> sol, Cu/Alu  
70-240 mm<sup>2</sup> sol (sector), Cu/Alu  
tightening torque terminal: 22.0 Nm

Prior to connection, aluminium conductors must be prepared according to the relevant technical recommendations.

**Further accessories and terminals  
(e.g. for aluminum cables) see  
Hensel main catalogue!**

**Accessories  
for solar inverter collectors**

**MS NH 00 NH bus-mounted fuse switch disconnector**

3-pole  
for retrofitting on busbars  
busbar thickness 10 mm and centreline spacing of busbars 60 mm  
rated current: 125 A  
rated voltage: AC 690 V  
terminal connection 5-70 mm<sup>2</sup> Cu

**Mi RS 18 D0 2-bus-mounted fuse base**

63 A, E 18, D0 2, Neozed, width: 36 mm  
3-pole  
rated voltage: AC 400 V  
with cover  
busbar thickness 10 mm and centreline spacing of busbars 60 mm  
for replacement in Mi-HRC fuse boxes, neozed  
rated connecting capacity: sol/s/f 1,5 - 25 mm<sup>2</sup>, Cu

**Mi BA Blanking cover**

for sealing protection covers with cut-outs for bus-mounted fuse bases  
in Mi-screw-type fuse boxes, diazed or neozed  
width: 108 mm

**Mi BA 6 Blanking cover**

for sealing protection covers  
in Mi-HRC fuse boxes  
width: 108 mm

**Mi WD 2 Wall gasket**

for the assembly of Mi boxes  
box walls 150 or 300 mm  
consisting of 1 seal, 4 wedge links, 1 bracket

**Mi SV 25 Busbar connector**

5-pole  
busbar rated current 250 A  
with wall gasket  
for the assembly of Mi boxes containing busbars  
tightening torque for terminal 6,0 Nm  
Busbars 250 A and 400 A can only be connected with busbar connector Mi SV 25.  
Connecting of busbars with different rated current only under care and attention of the corresponding short circuit and overload standards.

**Mi BE Fixing spares**

for the assembly of Mi boxes  
when converting existing installations  
consisting of 4 wedge links and 5 wedges

**AS 12 Blanking strip**

for the covering of spare equipment openings, for material thickness up to 3 mm  
12 modules 18 mm each  
divisible every 9 mm  
colour grey, similar RAL 7035

**Mi FP 15 Flange**

with fixing wedges and seal  
box wall 150 mm  
without knockouts

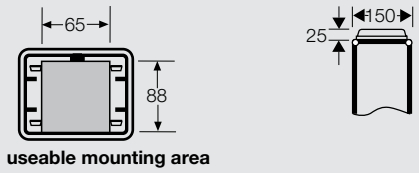
**Mi FM 15 Flange**

with fixing wedges and seal  
box wall 150 mm  
knockouts:  
3 x M 20, 1 x M 32/40/50

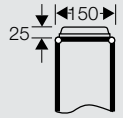
**Mi FP 20 Flange**

with fixing wedges and seal  
box wall 300 mm  
without knockouts

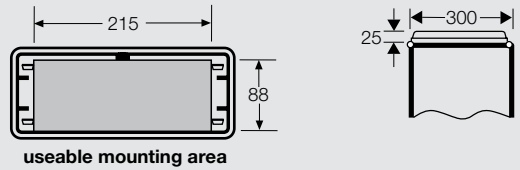
**Mi FM 20 Flange**

with fixing wedges and seal  
box wall 300 mm  
knockouts:  
15 x M 16, 15 x M 20

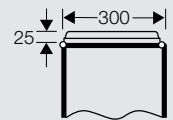
**Mi FM 25 Flange**

with fixing wedges and seal  
box wall 300 mm  
knockouts:  
19 x M 16/25

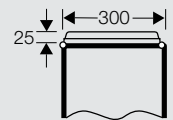
**Mi FM 32 Flange**

with fixing wedges and seal  
box wall 300 mm  
knockouts:  
8 x M 25/32, 1 x M 25/32/40

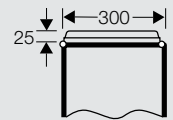
**Mi FM 40 Flange**

with fixing wedges and seal  
box wall 300 mm  
knockouts:  
2 x M 25/32, 5 x M 32/40

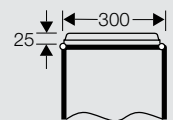
**Mi FM 50 Flange**

with fixing wedges and seal  
box wall 300 mm  
knockouts:  
2 x M 20, 4 x M 32/40/50

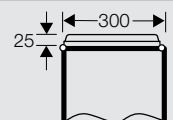
**Mi FM 60 Flange**

with fixing wedges and seal  
box wall 300 mm  
knockouts:  
3 x M 40/50/63

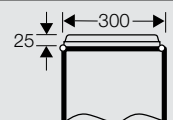



**Mi FP 38 Flange**

with fixing wedges and seal  
cable entry via integrated elastic membranes  
degree of protection: IP 65  
box wall 300 mm  
sealing range:  
29 x Ø 7-12 mm  
4 x Ø 7-14 mm  
4 x Ø 11-20 mm  
1 x Ø 16-29 mm

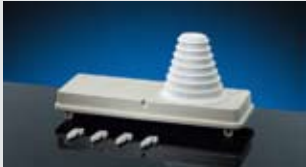
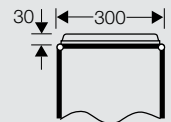

**Mi FP 70 Flange**

with fixing wedges and seal  
using 1 cable entry  
max. 72 mm external diameter  
degree of protection: IP 65  
box wall 300 mm  
sealing range: Ø 30-72 mm

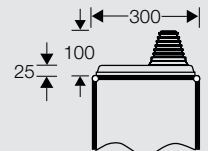

**Mi FP 72 Flange**

with fixing wedges and seal  
for 2 cables  
max. 72 mm external diameter  
degree of protection: IP 65  
box wall 300 mm  
sealing range: 2 x je Ø 30-72 mm

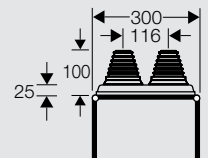

**Mi FM 63 Flange**

with fixing wedges and seal  
with extended cable arrangement space  
degree of protection: IP 65  
box wall 300 mm  
knockouts:  
3 x M 40/50/63

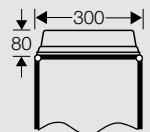

**MI FP 82 Cable insert**

for 2 cables  
max. 72 mm external diameter  
degree of protection IP 54 only with additional strain and pressure relief (e.g. Mi ZE 62)  
divisible for cable insertion from the front  
box wall 300 mm  
sealing range: 2 x Ø each 30-72 mm

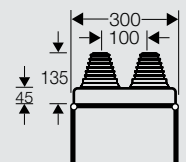

**Mi ZE 62 Cable strain relief**

for 2 cables with max. 60 mm external diameter  
with fixing rail 284 mm long  
to be used only in connection with cable insertion Mi FP 82  
cannot be installed in Mi 6856



**Mi BF 20 Ventilation flange**

for ventilation of Mi-Distribution boards  
in the event of extremely high internal temperatures or a risk of water condensation  
for vertical installation on the lateral box walls  
degree of protection IP 23

- for indoor (normal environment and/or protected outdoor) and outdoor installation (harsh environment and/or outdoor)
- with strain relief and locknut

- material: thermoplastic
- **degree of protection: IP 65**
- **colour: grey, RAL 7035**



Cable glands				
<b>AKM 12</b>	ISO thread M 12 x 1,5	Sealing range Ø 3-6,5 mm	Bore-hole Ø 12,5 mm	Wall thickness bis 3 mm
<b>AKM 16</b>	ISO thread M 16 x 1,5	Sealing range Ø 5-10 mm	Bore-hole Ø 16,5 mm	Wall thickness bis 3 mm
<b>AKM 20</b>	ISO thread M 20 x 1,5	Sealing range Ø 6,5-13,5 mm	Bore-hole Ø 20,5 mm	Wall thickness bis 3 mm
<b>AKM 25</b>	ISO thread M 25 x 1,5	Sealing range Ø 10-17 mm	Bore-hole Ø 25,5 mm	Wall thickness bis 3 mm
<b>AKM 32</b>	ISO thread M 32 x 1,5	Sealing range Ø 14-21 mm	Bore-hole Ø 32,5 mm	Wall thickness bis 3 mm
<b>AKM 40</b>	ISO thread M 40 x 1,5	Sealing range Ø 20-28 mm	Bore-hole Ø 40,5 mm	Wall thickness bis 3 mm
<b>AKM 50</b>	ISO thread M 50 x 1,5	Sealing range Ø 25-35 mm	Bore-hole Ø 50,5 mm	Wall thickness bis 3 mm
<b>AKM 63</b>	ISO thread M 63 x 1,5	Sealing range Ø 35-48 mm	Bore-hole Ø 63,5 mm	Wall thickness bis 3 mm

- for indoor (normal environment and/or protected outdoor) and outdoor installation (harsh environment and/or outdoor)
- with strain relief and locknut

- material: thermoplastic
- **degree of protection: IP 66 / IP 67**
- **colour: black, RAL 9005**



Cable glands				
<b>ASS 12</b>	ISO thread M 12 x 1,5	Sealing range Ø 2-5 mm	Bore-hole Ø 12,5 mm	Wall thickness bis 3 mm
<b>ASS 16</b>	ISO thread M 16 x 1,5	Sealing range Ø 3-10 mm	Bore-hole Ø 16,5 mm	Wall thickness bis 3 mm
<b>ASS 20</b>	ISO thread M 20 x 1,5	Sealing range Ø 5-13,5 mm	Bore-hole Ø 20,5 mm	Wall thickness bis 3 mm
<b>ASS 25</b>	ISO thread M 25 x 1,5	Sealing range Ø 8-17 mm	Bore-hole Ø 25,5 mm	Wall thickness bis 3 mm
<b>ASS 32</b>	ISO thread M 32 x 1,5	Sealing range Ø 12-21 mm	Bore-hole Ø 32,5 mm	Wall thickness bis 3 mm
<b>ASS 40</b>	ISO thread M 40 x 1,5	Sealing range Ø 16-28,5 mm	Bore-hole Ø 40,5 mm	Wall thickness bis 3 mm
<b>ASS 50</b>	ISO thread M 50 x 1,5	Sealing range Ø 21-35 mm	Bore-hole Ø 50,5 mm	Wall thickness bis 3 mm
<b>ASS 63</b>	ISO thread M 63 x 1,5	Sealing range Ø 27-48 mm	Bore-hole Ø 63,5 mm	Wall thickness bis 3 mm

- for indoor (normal environment and/or protected outdoor) and outdoor installation (harsh environment and/or outdoor)
- with strain relief and locknut
- material: thermoplastic
- **degree of protection: IP 66 / IP 67**
- **colour KBM: grey, RAL 7032**
- **colour KBS: schwarz, RAL 9005**

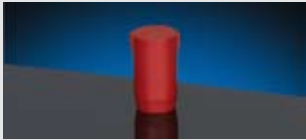

**Combi climate gland**

<b>KBM 20</b>	ISO thread	sealing range	bore-hole	wall thickness
<b>KBS 20</b>	M 20 x 1,5	Ø 6-13 mm	Ø 20,5 mm	up to 3,5 mm

In order not to exceed leakage limit of 0.07 bar with pressure compensation, **one combi climate gland M20 must be used per 6 litres (6000 cm³)** of enclosure volume.  
 Example: enclosure size 27 cm x 27 cm x 17 cm = 12393 cm³ = 12.393 litres.  
 Number of necessary KB. 20 (M20) ≥ 3 pieces.

<b>KBM 25</b>	ISO thread	sealing range	bore-hole	wall thickness
<b>KBS 25</b>	M 25 x 1,5	Ø 9-17 mm	Ø 25,5 mm	up to 3,5 mm

In order not to exceed leakage limit of 0.07 bar with pressure compensation, **one combi climate gland M25 must be used per 11 litres (11000 cm³)** of enclosure volume.  
 Example: enclosure size 27 cm x 27 cm x 17 cm = 12393 cm³ = 12.393 litres.  
 Number of necessary KB. 25 (M25) ≥ 2 pieces

<b>KBM 32</b>	ISO thread	sealing range	bore-hole	wall thickness
<b>KBS 32</b>	M 32 x 1,5	Ø 13-21 mm	Ø 32,5 mm	up to 3,5 mm

In order not to exceed leakage limit of 0.07 bar with pressure compensation, **one combi climate gland M32 must be used per 13 litres (13000 cm³)** of enclosure volume.  
 Example: enclosure size 27 cm x 27 cm x 17 cm = 12393 cm³ = 12.393 litres.  
 Number of necessary KB. 32 (M32) ≥ 1 piece.

**VSB 13 Sealing plug**

diameter: 13 mm  
 for sealing combi climate glands M20 or M25, which are not used for cable entry  
 material: thermoplastic  
 colour: red, RAL 3000

**VSB 21 Sealing plug**

diameter: 21 mm  
 for sealing combi climate glands M25 or M32, which are not used for cable entry  
 material: thermoplastic  
 colour: red, RAL 3000

For adherence to the requested degree of protection the ventilation of the enclosure is effected via a special combi climate gland.

Via an inserted, breathable membrane combi climate glands ensure pressure compensation between enclosure interior and ambient air.

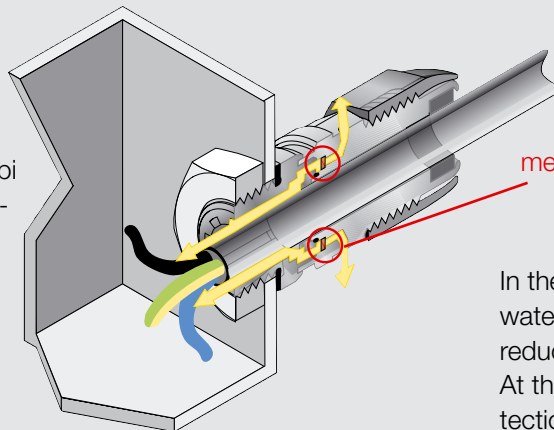

The ingress of humidity from outside is prevented by this

membrane.

In the consequence accumulated water dries by air exchange away or reduces itself in the course of time. At the same time the degree of protection of the enclosure is obtained (up to IP 67)!

When using different gland sizes the values for the enclosure volumes of the used combi climate glands can be added on. If the quantity of the necessary climate glands for pressure compensation is larger, than the number of necessary cable glands für cable entry, the unused climate glands can be sealed with sealing plugs.



**Mi PL 2    Sealing caps**

2 sealing caps for converting the lid fasteners



**Mi SR 4    Conversion set**

4 fastening covers  
for converting lid fasteners for manual operation to tool operation



**Mi SN 4    Conversion set**

4 manual actuators  
for converting lid fasteners from tool operation to manual operation



**Mi DV 01    Locking device insertion**

only in connection with Mi PL 2, Mi SR 4 or Mi SN 4



**Mi ZS 11    Lid lock**

locking device I  
Is being used instead of fasteners for hand or tool operation  
in order to prevent unauthorised opening of the lids  
consisting of: cylinder lock, key, locking device insertion, dust cover



**Mi ZS 12    Lid lock**

locking device II  
Is being used instead of fasteners for hand or tool operation  
in order to prevent unauthorised opening of the lids  
consisting of: cylinder lock, key, locking device insertion, dust cover



**Mi DR 04    Lid fastener for tool operation**

triangle 8 mm  
is used instead of fasteners for hand- or tool operation, in order to make unauthorized opening of lids mor difficult  
4 locking devices with triangle 8 mm and key



**Mi SA 2    Dust protection cover**

for 2 lid fittings  
for box sizes 1 to 4



**Mi AL 40 Stainless steel external brackets**

for external box fixing with Mi enclosures  
set consisting of 4 fixing brackets, 4 screws

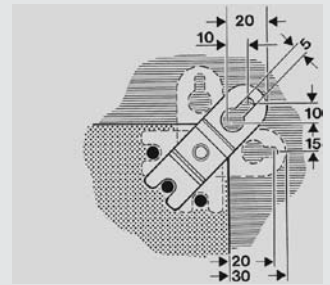

**Mi MS 2 Mounting profile**

for wall-mounted assembly of Mi-distribution boards  
up to 900x1200 mm  
with 8 screws M6 x 16 for box fixing  
sendzimir galvanised steel profile with structured powder  
coating  
colour RAL 7032 grey  
length 1950 mm

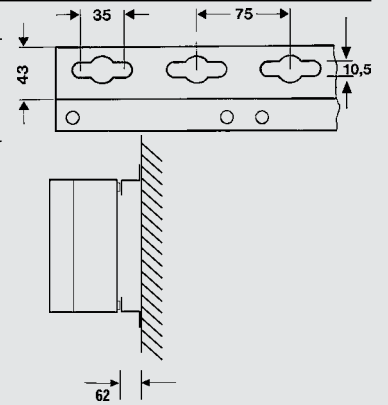



<b>Operating and ambient conditions</b>	<b>KF PV.., KV PC.., KV PV ..., Mi PV..</b>	<b>Cable glands</b>	
		<b>AKM</b>	<b>ASS</b>
<b>Application area</b>	<b>KF PV-, KV PC-, KV PV ..., Mi PV enclosures and cable glands are suitable for the outdoor installation - harsh environment and / or outdoor.</b> However the climatic influences and effects on the equipment are to be considered. <sup>1)</sup>		
<b>Ambient temperature</b> - Average value over 24 hours - Maximum value - Minimum value	+ 35° C + 40° C - 5° C	+ 55° C + 70° C - 25° C	+ 55° C + 70° C - 25° C
<b>Relative humidity</b> - short-time	50% at 40° C 100% at 25° C		
<b>Fire protection</b> in the event of internal faults	<b>Demands</b> placed on electrical devices from standards and laws  <b>Minimum requirements</b> - Glow wire test in accordance with IEC 60 695-2-11: - 650° C for boxes and cable glands - 850° C for conducting components		
<b>Fire protection</b> <b>in the event of</b> <b>specific risks or hazards</b>	<b>Demands</b> placed on electrical installations and devices in areas and facilities subject to fire risk, e.g. DIN VDE 0100 Part 482, official regulations, VdS directives  <b>Minimum requirements</b> - Glow wire test in accordance with IEC 60 695-2-11: - 850° C for boxes and cable glands - 850° C for cavity wall installation - Use of fire resistant cables		
<b>Burning behaviour</b> - Glow wire test IEC 60 695-2-11 - UL Subject 94	960° C V-2 flame-retardant self-extinguishing	750° C V-2 flame-retardant self-extinguishing	960° C V-2 flame-retardant self-extinguishing
<b>Degree of protection against mechanical load</b>	IK 08 (5 Joule)		
<b>Toxic behaviour</b>	halogen-free <sup>2)</sup> silicone-free		

1) Supplementing references regarding outdoor installation - harsh environment and / or outdoor:  
 - The materials used for the Mi System are basically UV resistant, so that the mechanical resistance of the boxes is maintained during UV effect.  
 Depending on the intensity of the UV effect e.g. transparent lids can become intransparent.  
 - The top side of the boxes should be protected by a cover against weather influences such as rains, ice and snow.  
 - Further on, also chemical influences have to be considered with the selection of the installation place - apart from the IP rating and climatic effects.  
 - In order to keep the maximum permissible ambient temperature of the installed equipment as well as for the prevention from condensation additional measures as ventilation and/or heating may be necessary.

2) "Halogen-free" in accordance with IEC 754-2 "Common test methods for cables - Determination of the amount of halogen acid gas".

Outside diameter of conventional cable cross sections. The outside diameters are average values of different products.

Cable cross section	NYM	NYY	NYCY NYCWY
mm <sup>2</sup>	mm Ø	mm Ø	mm Ø
1x4	8	9	—
1x6	8,5	10	—
1x10	9,5	10,5	—
1x16	11	12	—
1x25	—	14	—
1x35	—	15	—
1x50	—	16,5	—
1x70	—	18	—
1x95	—	20	—
1x120	—	21	—
1x150	—	23	—
1x185	—	25	—
1x240	—	28	—
1x300	—	30	—
2x1,5	10	12	—
2x2,5	11	13	—
2x4	—	15	—
2x6	—	16	—
2x10	—	18	—
2x16	—	20	—
2x25	—	—	—
2x35	—	—	—
3x1,5	10,5	12,5	13
3x2,5	11	13	14
3x4	13	16	16
3x6	15	17	17
3x10	18	19	18
3x16	20	21	21
3x25	—	26	—
3x35	—	—	—
3x50	—	—	—
3x70	—	—	—
3x95	—	—	—
3x120	—	—	—
3x150	—	—	—
3x185	—	—	—
3x240	—	—	—
3x25/16	—	27	27
3x35/16	—	28	27
3x50/25	—	32	32
3x70/35	—	32-36	36
3x95/50	—	37-41	40
3x120/70	—	42	43
3x150/70	—	46	47
3x185/95	—	52	48-54
3x240/120	—	57-63	60
3x300/150	—	63-69	—

Cable cross section	NYM	NYY	NYCY NYCWY
mm <sup>2</sup>	mm Ø	mm Ø	mm Ø
4x1,5	11	13,5	14
4x2,5	12,5	14,5	15
4x4	14,5	17,5	17
4x6	16,5	18	18
4x10	18,5	20	20
4x16	23,5	23	23
4x25	28,5	28	28
4x35	32	26-30	29
4x50	—	30-35	34
4x70	—	34-40	37
4x95	—	38-45	42
4x120	—	42-50	47
4x150	—	46-53	52
4x185	—	53-60	60
4x240	—	59-71	70
4x25/16	—	—	30
4x35/16	—	—	30
4x50/25	—	—	36,5
4x70/35	—	—	40
4x95/50	—	—	44,5
4x120/70	—	—	48,5
4x150/70	—	—	53
4x185/95	—	—	—
4x240/120	—	—	—
5x1,5	12	15	15
5x2,5	13,5	16	17
5x4	15,5	16,5	18
5x6	18	19	20
5x10	20	21	—
5x16	26	24	—
5x25	31,5	—	—
7x1,5	13	16	—
7x2,5	14,5	16,5	—
19x1,5	—	22	—
24x1,5	—	25	—

Assignment of cable outside diameters to cable entries (glands, grommets etc.)

Outside diameters of cables		Cable entry metric
min. mm Ø	max. mm Ø	
3	6	ASM/AKM/ASS 12
5	10	ASM/AKM/ASS 16
6,5	13,5	ASM/AKM/ASS 20
11	17	ASM/AKM/ASS 25
15	21	ASM/AKM/ASS 32
19	28	ASM/AKM/ASS 40
27	35	ASM/AKM/ASS 50
35	48	ASM/AKM/ASS 63
4,8	11	ESM 16
6	13	ESM 20
9	17	ESM 25
9	23	ESM 32
17	30	ESM 40
3,5	12	STM 16
5	16	STM 20
5	21	STM 25
13	26,5	STM 32
13	34	STM 40

Outside diameters of cables		Cable entry metric
min. mm Ø	max. mm Ø	
5	10	EDK 16
6	13	EDK 20
9	17	EDK 25
8	23	EDK 32
11	30	EDK 40
conduit connection		
M 16		EDR 16
M 20		EDR 20
M 25		EDR 25
M 32		EDR 32
M 40		EDR 40

Material properties	used with product	material	Glow wire test IEC 60 695-2-11	UL Subject 94	Temperatur- beständigkeit	Chemical resistance <sup>1)</sup>					
						Acid 10 %	Lye 10 %	Alcohol	Petrol (MAK) <sup>2)</sup>	Benzene (MAK) <sup>2)</sup>	Mineral oil
	<b>Lids of Mi distribution boards doors of KV small-type distribution boards</b>	PC (polycarbonate)	960° C	V-2	-40° C / +120° C	+	+	0	+	-	+
	<b>Bottom parts of Mi distribu- tion boards and KV small- type distribution boards</b>	PC-GFS (polycarbonate)	960° C	V-0	-40° C / +120° C	+	+	0	+	-	+
	<b>Mi ... KV ...</b>	PUR (polyurethane)	—	—	-25° C / +80° C	0	+	0	0	-	+
	<b>Mi FP 38 KV ...</b>	TPE (thermoplastic elastomer)	750° C	—	-25° C / +100° C	+	+	+	0	0	0
	<b>AKM ..</b>	PA (polyamide)	960° C	V-0	-40° C / +100° C	+	0	+	+	+	+
	<b>ASS .. , KBM .. , KBS ..</b>	PA (polyamide)	960° C	V-2	-40° C / +100° C	+	0	+	+	+	+
	<b>AKM .. , ASS ..</b>	PA (polyamide)	750° C	V-2	-40° C / +100° C	+	0	+	+	+	+
	<b>AKM .. , ASS ..</b>	CR/NBR (polychloroprene - nitrile rubber)	—	—	-20° C / +100° C	+	+	+	0	-	0
	<b>ASS ..</b>	TPE (Evoprene)	—	—	-20° C / +100° C	+	-	+	-	-	-
	<b>ASS ..</b>	CR (chloroprene rubber)	—	—	-30° C / +100° C	+	+	+	0	-	0
	<b>KBM .. , KBS ..</b>	EPDM ethylene propylene diene monomer rubber	—	—	-40° C / +130° C	+	+	+	-	-	-

1) The specifications on chemical resistance are a general guide. In individual cases it may be necessary to check resistance in combination with other chemicals and ambient conditions (temperature, concentration, etc.)

2) (MAK) - Maximum allowable concentration (work place)

**Generator junction boxes and solar inverter collector comply with the requirements for type-tested switchgear and controlgear assemblies (TTA) in accordance with IEC 60 439-1/ EN 60 439-1.**

Type-tested switchgear assemblies are switchgear and controlgear assemblies which are assembled and wired according to manufacturer data without essential deviations from the original type or system.

To meet these requirements for Hensel Mi Distribution boards, the following must be noted:

1. The switchgear must consist of the type-tested enclosures documented in this list.
2. The wiring of the equipment must be carried out with the cross-sections and conductor types indicated in Table "Rating of insulated conductors in switchgear assemblies", Index Technics.
3. Once the switchgear is completed, a routine test must be carried out in accordance with this standard
4. The test must be certified with a test report.
5. The switchgear must be provided with a manufacturer's identification mark.  
Compliance with important data such as
  - limit of temperature rise
  - dielectric strength
  - short-circuit withstand capacity
  - short-circuit withstand capacity of the PE conductor
  - IP degrees of protection
  - creepage distances and clearancesis verified by type tests for this system.

#### **Standards and requirements**

- IEC 60 439-1  
Low voltage switchgear and control gear assemblies
- IEC 60 999  
Safety requirements for screw-type and screwless-type clamping units for electrical copper conductors
- DIN EN 50 262  
Metric threaded cable glands for electrical installations
- IEC 60 269  
Low voltage fuses
- DIN 43 880  
Built-in equipment for electrical installations;  
overall dimensions and related mounting dimensions
- IEC 60 529  
Degrees of protection provided by enclosures (IP-Code)
- IEC 60 364-712  
Electrical installations of buildings  
Requirements for special installations or locations –  
Solar photovoltaic (PV) power supply systems



Request/offer

Order

Date: \_\_\_\_\_

Gustav Hensel GmbH & Co. KG · Industrial Electrical Power Distribution Systems  
Altenhundem · Gustav-Hensel-Straße 6 · D-57368 Lennestadt · Germany · www.hensel-electric.de  
Phone: 027 23/609-423 · Fax: 027 23/609-371 · E-Mail: enysun@hensel-electric.de · www.enysun.eu

**Contractor:**

**Project:**

Name: \_\_\_\_\_

\_\_\_\_\_

Address: \_\_\_\_\_

\_\_\_\_\_

\_\_\_\_\_

\_\_\_\_\_

Tel. (for any questions): \_\_\_\_\_

- protection class II
- suitable for outdoor installation, UV resistant
- ready for connection
- with external stainless steel bracket for box mounting

- lid fasteners for tool operation
- material: thermoplastic
- colour: grey, RAL 7032
- degree of protection IP 65

**Rated voltage:**  DC 600 V  DC 1000 V

**Number of boxes:** \_\_\_\_\_ pieces

**Number of strings per box:**  1  2  3  4  \_\_\_\_\_

**Current per string:**  15 A  30 A  \_\_\_\_\_

**Connection of strings coming from PV modules:**  Multi Contact MC4-compatible  \_\_\_\_\_

- Screw connection and screw terminals
- Screw connections and screw-less terminals

**Cable cross-section:**  \_\_\_\_\_ mm<sup>2</sup>

**Solar inverter feeding (MPP tracker)**  1  2  3  \_\_\_\_\_

**Connection of conductors going to inverter:**  Multi Contact MC4-compatible  \_\_\_\_\_

- Screw connection and screw terminals
- Screw connections and screw-less terminals

**Cable cross-section:**  \_\_\_\_\_ mm<sup>2</sup>

**Overvoltage protection:**  no  type 1  type 2  Floating remote indication

**Manufacturer:**  Dehn  Phoenix  OBO Bettermann  \_\_\_\_\_

**DC generator disconnect switch:**  yes  no

**String overload protection:**  yes  no

**Blocking diodes:**  yes  no

**Earthing**

**Cable type and diameter:**  NYY 1 x 16 mm<sup>2</sup>  \_\_\_\_\_

**Cable entry:**  Cable glands  also for additional ventilation  
 Combi climate glands  \_\_\_\_\_

**Notes:**



Request/offer

Order

Date: \_\_\_\_\_

Gustav Hensel GmbH & Co. KG · Industrial Electrical Power Distribution Systems  
Altenhundem · Gustav-Hensel-Straße 6 · D-57368 Lennestadt · Germany · www.hensel-electric.de  
Phone: 027 23/609-423 · Fax: 027 23/609-371 · E-Mail: enysun@hensel-electric.de · www.enysun.eu

Contractor:

Project:

Name: \_\_\_\_\_

\_\_\_\_\_

Address: \_\_\_\_\_

\_\_\_\_\_

Tel. (for any questions): \_\_\_\_\_

- protection class II
- suitable for outdoor installation, UV resistant
- with external stainless steel bracket for box mounting

- material: thermoplastic
- colour: grey, RAL 7032

Rated voltage:  AC 230/400 V  \_\_\_\_\_

<b>Inverter Manufacturer/type:</b>				
<b>Quantity:</b> (pieces)				
<b>Output:</b> (kW)				
<b>Current:</b> (A)				
<b>Solar inverter connection:</b> 1~/3~	<input type="checkbox"/> / <input type="checkbox"/>	<input type="checkbox"/> / <input type="checkbox"/>	<input type="checkbox"/> / <input type="checkbox"/>	<input type="checkbox"/> / <input type="checkbox"/>
<b>Cable going to inverter:</b>	<b>Type of cable:</b>			
	<b>Number of conductors:</b>			
	<b>Cross-section:</b>			
	<b>Conductor material:</b>			
<b>RCD (residual current protective):</b>	<input type="checkbox"/> yes <input type="checkbox"/> no			
<b>Wire protection to solar inverter:</b>	<input type="checkbox"/> MCB <input type="checkbox"/> fuse element <input type="checkbox"/> fuse switch disconnecter			
<b>Cable going to distribution board:</b>	<b>Type of cable:</b>			
	<b>Number of conductors:</b>			
	<b>Cross-section:</b>			
	<b>Conductor material:</b>			

Overvoltage protection:  no  type 1  type 2  floating remote indication

Manufacturer:  Dehn  Phoenix  OBO Bettermann  \_\_\_\_\_

Cable entry:  with strain relief  without strain relief

Installation site:  unprotected outdoors  protected outdoors  
 indoors  \_\_\_\_\_

Degree of protection:  IP 65  IP 54  IP 23

Notes:  
\_\_\_\_\_  
\_\_\_\_\_



ENYSUN

**Declaration of EC Conformity  
ENYSUN**

**Erklärung  
der EG-Konformität**

**Nr./No. ENY 2010**

*Declaration of EC-Conformity*

Das Produkt,  
*The product*

Bezeichnung/Name: **ENYSUN**  
Typen/Types: **Mi PV....., KV PV....., KV PC....., KF PV....**

Hersteller: **Gustav Hensel GmbH & Co. KG**  
Manufacturer **Gustav-Hensel-Straße 6**  
**57368 Lennestadt**

Beschreibung: **Generatoranschlusskästen und Wechselrichtersammler für PV-Anlagen**  
Description: **Generator junction boxes and solar inverter collectors for PV plants**

auf das sich diese Erklärung bezieht, stimmt mit folgenden Normen oder normativen Dokumenten überein:  
*to which this declaration relates is in conformity with the following standard(s) or normative document(s):*

Norm/ Standard: **EN 61439-2**  
**IEC 61439-2**

und entspricht den Bestimmungen der folgenden EG-Richtlinie(n):  
*and is in accordance with the provisions of the following EC-directive(s)*

**Niederspannungs-Richtlinie 2006/95/EG**  
**Low voltage directive 2006/95/EC**

Diese Konformitätserklärung entspricht der Europäischen Norm EN 17050-1 „Allgemeine Anforderungen für Konformitätserklärungen von Anbietern“. Das Unternehmen Gustav Hensel GmbH & Co. KG ist Mitglied von ALPHA, Gesellschaft zur Prüfung und Zertifizierung von Niederspannungsgeräten e.V.. Diese Erklärung gilt weltweit als Erklärung des Herstellers zur Übereinstimmung mit den oben genannten internationalen und nationalen Normen.

*This Declaration of Conformity is suitable to the European Standard EN 17050-1 „General requirements for supplier's declaration of conformity“. The company Gustav Hensel GmbH & Co. KG is member of ALPHA, Association for testing and certification of low voltage equipment. The declaration is world-wide valid as the manufacturer's declaration of compliance with the requirements of the a.m. national and international standards.*

Jahr der Anbringung der  
CE-Kennzeichnung: **2010**  
*Year of affixing CE-Marking*

Ausstellungsdatum: **01.06.2010**  
*Date of issue*

Gustav Hensel GmbH & Co. KG

R. Cater   
- Technische Geschäftsleitung -  
- *Technical Managing Director* -



● **Foreign partnerships**

**Czech Republic**  
Hensel s.r.o.

**Hungary**  
Hensel Hungaria Villamosági Kft

**Poland**  
Hensel Polska Sp. z o. o.

**Russia**  
Hensel Elektro GmbH

**Turkey**  
Hensel Electric Turkey Ltd.

**India**  
Hensel Electric India Pvt. Ltd

**People's Republic of China**  
Hensel (Qingdao)  
Electrotechnical Installation Systems Co. Limited

● **Agents / Representatives**

Africa	Asia	Europe	Middle East
Angola Egypt	Bangladesh Bhutan Cambodia	Austria Belgium Bulgaria Croatia Czech Republic Denmark Estonia Finland France Greece Great Britain Hungary Ireland Italy Israel Serbia and Montenegro	Latvia Lithuania Luxembourg Netherlands Norway Poland Portugal Romania Russia Spain Sweden Switzerland Slovakia Turkey Ukraine
<b>America</b> Argentina USA	People's Republic of China Georgien India Indonesia Kazakhstan Malaysia Maldives Pakistan Philipines Singapore Sri Lanka Taiwan Thailand		Regional Office Middle East (Dubai), United Arab Emirates  Bahrain Iran Oman Qatar Kuwait Saudi Arabia
			<b>Ozeanien</b> Australia New Zealand

# Here comes the sun!

Photovoltaic plants  
installed quickly,  
in adherence with  
standards, and safely.



**NEW**

ENYSUN is here at last. Now there is no longer any problem selecting and installing photovoltaic plants safely. Hensel has the professional solution. ENYSUN, the safe photovoltaic distributors that comply with the standards, the plant is quickly, easily and safely installed, from the roof to the mains supply. Clear competitive advantages for you - from Hensel.

[www.enysun.eu](http://www.enysun.eu)